

MYSON * BEVI-WRIGHT * JBW PUMPS

SG RANGE



IN-LINE DIRECT COUPLED HEAVY COMMERCIAL PUMPS

Engineer Services

MYSON SG IN-LINE DIRECT COUPLED PUMPS –

ALTOGETHER A BETTER ALTERNATIVE

The Myson 'SG' range of single stage, in-line, direct coupled pumps offers today's heating and ventilating industry a family of heavy commercial pumps to meet even the most stringent of specifications in the circulation, transfer and booster applications of commercial chilled and hot water systems.

Designed and developed by Britain's foremost pump specialist, the 'SG' range offers a wide portfolio of options in terms of single and twin head configurations, motor sizes, and port diameters to ensure total compatibility with the most arduous of commercial systems applications.

Capable of operating at the extremes of temperature demanded by specifiers, 'SG' pumps will comfortably handle non-aggressive fluids ranging from -10°C to + 120°C.

Through robust construction, high specification of components and precision engineering to fine tolerances, the inclusion of 'SG' heavy commercial pumps in any system ensures maximum trouble-free operation and the reliability of a long working life from the unit.



The success of this design philosophy, backed up by the Potterton Myson stringent quality-control regime, offers the market a comprehensive range of glanded heavy commercial pumps with a level of reliability and endurance envied by others.



Ease of Precise Specification.

The 'SG' range offers the specifier a depth of range second to none in marrying the precise model to even the most complex of systems being designed.

A range of port diameters from 50mm (2") to 200mm (8") allow perfect system matching. Link to this the choice of single or twin-head units, cast iron or bronze pump bodies and the option of bronze impellers, and the 'SG' range can be closely 'tailored' to the exact requirements of the specifier without compromise.

With a choice of 1 and 3 phase A.C. motors, offering a range of motor speeds

from 950 to 2800 rev/min the 'SG' range can comply with any demands made upon it – whatever the installation.

Cost Effective Installation and Maintenance.

All 'SG' pumps, being of the in-line, direct coupled configuration, can be mounted with a vertical or horizontal shaft.

Mounting baseplates and blanking plates are included with all 'SG' twin pumps (and as an extra on the single head version if required).

For ease of maintenance, should it be required, the 'SG' range uses standard metric motors and Crane mechanical seals - both readily available should the unit require emergency maintenance, or indeed, long term replacement.

Precision Engineered in Britain.

All Myson 'SG' pumps are designed and manufactured in Britain. By employing the latest skills in precision engineering derived from expert design and development,

executed utilising the latest in engineering techniques we can ensure that, once installed, the 'SG' pump will provide years of trouble free service.

Nationwide Sales and Service.

With a specialist team of industrial representatives around the U.K., we are on hand to give expert advice on system design, specification and installation. We can assist you in maximising the efficiency of the installation through ensuring the total compatibility of the pump network to the demands of the system.

If you require technical advice by telephone, we have a telephone 'hotline', direct to Potterton Myson technical experts.

Full service and spares facilities are available in order to ensure that, once installed, the 'SG' pump will continue to perform, day in and day out, for years to come, as if it had just been fitted.

The Myson range is available from pump distributors and specialist merchants throughout the U.K.



SG Single Pumps

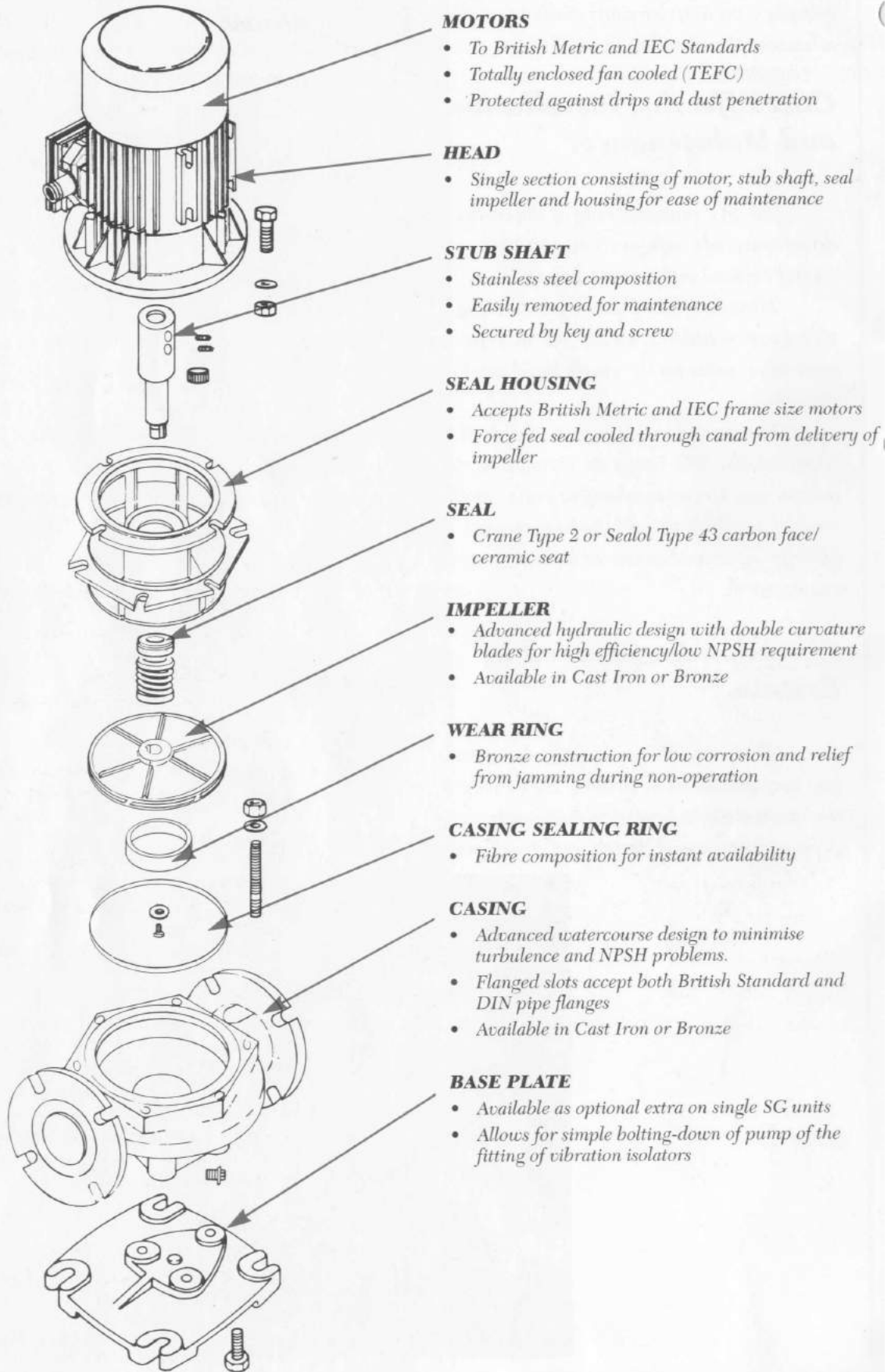

MOTORS

- To British Metric and IEC Standards
- Totally enclosed fan cooled (TEFC)
- Protected against drips and dust penetration

HEAD

- Single section consisting of motor, stub shaft, seal impeller and housing for ease of maintenance

STUB SHAFT

- Stainless steel composition
- Easily removed for maintenance
- Secured by key and screw

SEAL HOUSING

- Accepts British Metric and IEC frame size motors
- Force fed seal cooled through canal from delivery of impeller

SEAL

- Crane Type 2 or Sealol Type 43 carbon face/ ceramic seat

IMPELLER

- Advanced hydraulic design with double curvature blades for high efficiency/low NPSH requirement
- Available in Cast Iron or Bronze

WEAR RING

- Bronze construction for low corrosion and relief from jamming during non-operation

CASING SEALING RING

- Fibre composition for instant availability

CASING

- Advanced watercourse design to minimise turbulence and NPSH problems.
- Flanged slots accept both British Standard and DIN pipe flanges
- Available in Cast Iron or Bronze

BASE PLATE

- Available as optional extra on single SG units
- Allows for simple bolting-down of pump of the fitting of vibration isolators

SG Twin Pumps

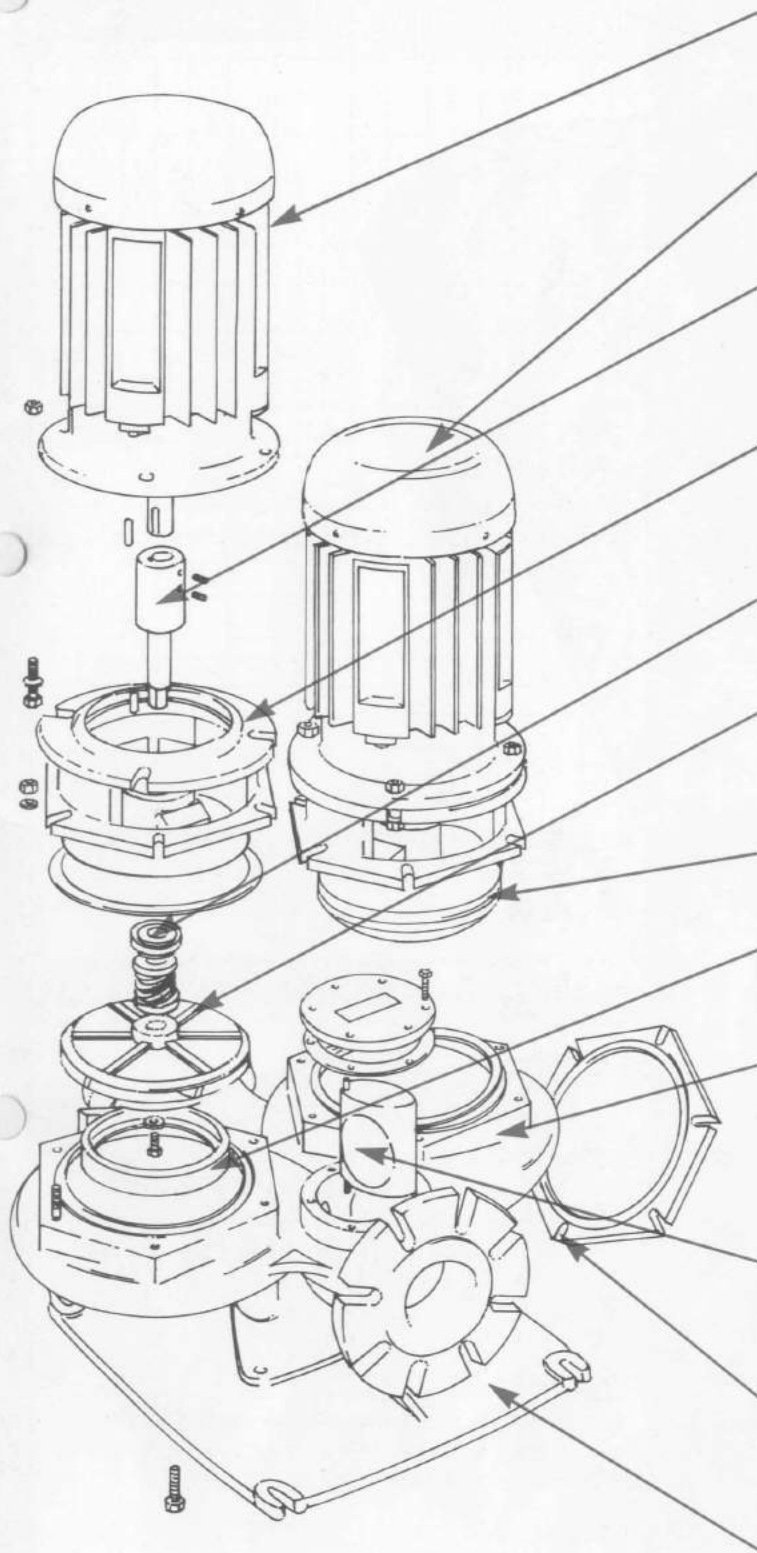

MOTORS

- To British Metric and IEC Standards
- Totally enclosed fan cooled (TEFC)
- Protected against drips and dust penetration

HEAD

- Single section consisting of motor, stub shaft, seal impeller and housing for ease of maintenance

STUB SHAFT

- Stainless steel composition
- Easily removed for maintenance
- Secured by key and screw

SEAL HOUSING

- Accepts British Metric and IEC frame size motors
- Force fed seal cooled through canal from delivery of impeller

SEAL

- Crane Type 2 or Sealol Type 43 carbon face/ceramic seat

IMPELLER

- Advanced hydraulic design with double curvature blades for high efficiency/low NPSH requirement
- Available in Cast Iron or Bronze

CASING SEALING RING

- Fibre composition for instant availability

WEAR RING

- Bronze construction for low corrosion and relief from jamming during non-operation

CASING

- Advanced watercourse design to minimise turbulence and NPSH problems.
- Flanged slots accept both British Standard and DIN pipe flanges
- Available in Cast Iron or Bronze

FLAP VALVE

- Eliminates reverse circulation through standby pump but allows running of both pumps simultaneously if required

BLANKING PLATE

- Supplied as standard on twin SG units
- Permits running of standby unit when other head removed for maintenance

BASE PLATE

- Standard item on twin SG units
- Allows for simple bolting-down of pump of the fitting of vibration isolators

Primary Selection Chart - SG Single

2900 rev/min

* 65.2175 appears here

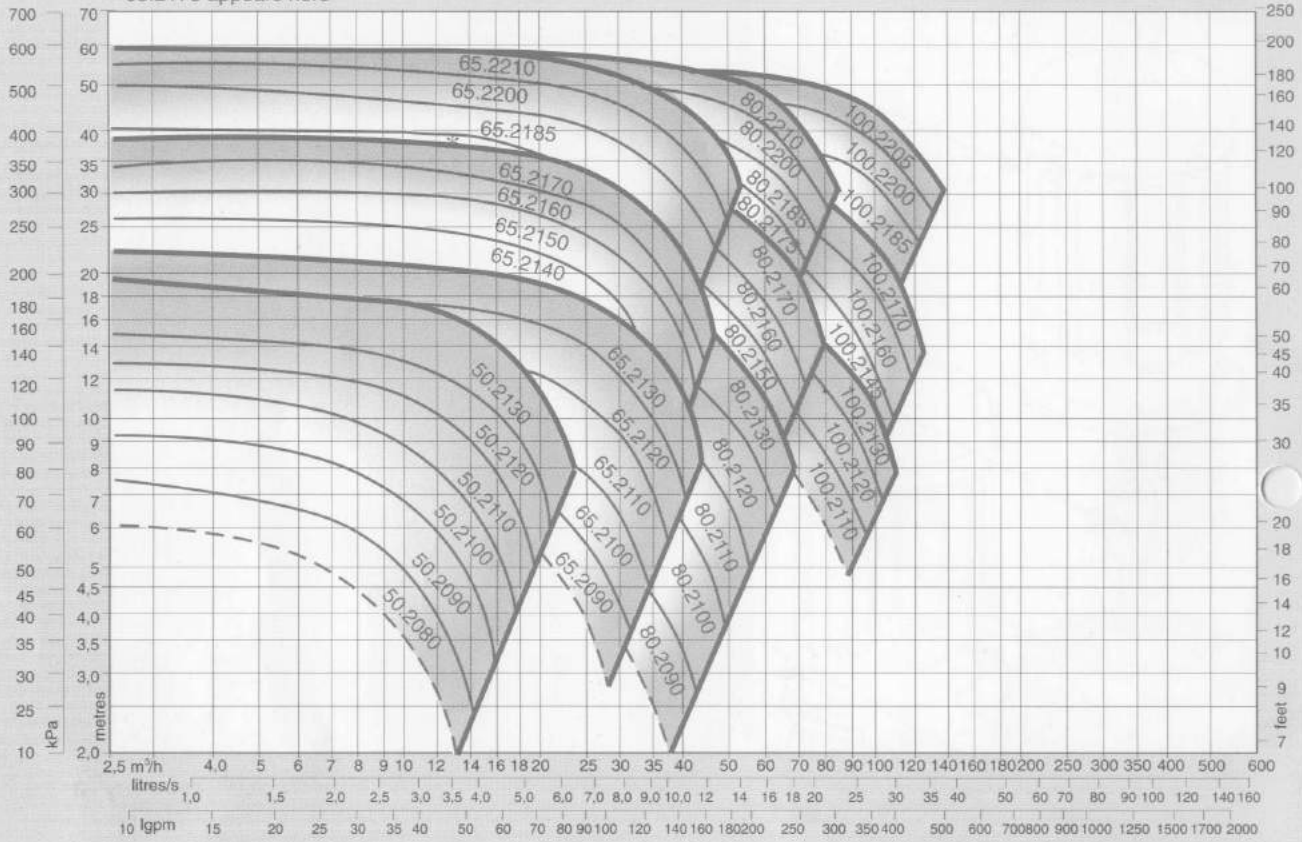

1450 & 950 rev/min

*(1)100.4220 appears here *(2)125.4260 *(3)125.4250 *(4)125.4235 appears here

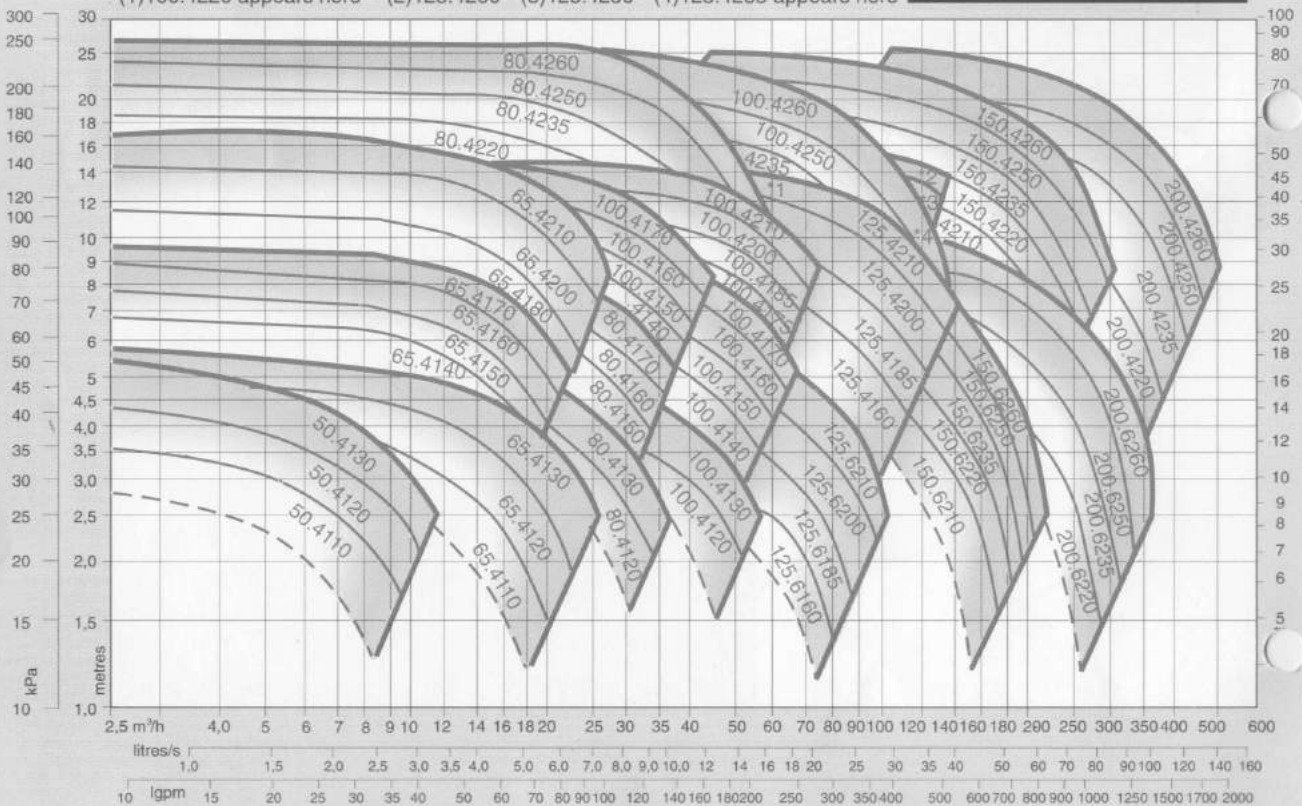

Primary Selection Chart - SG Double

2900 rev/min

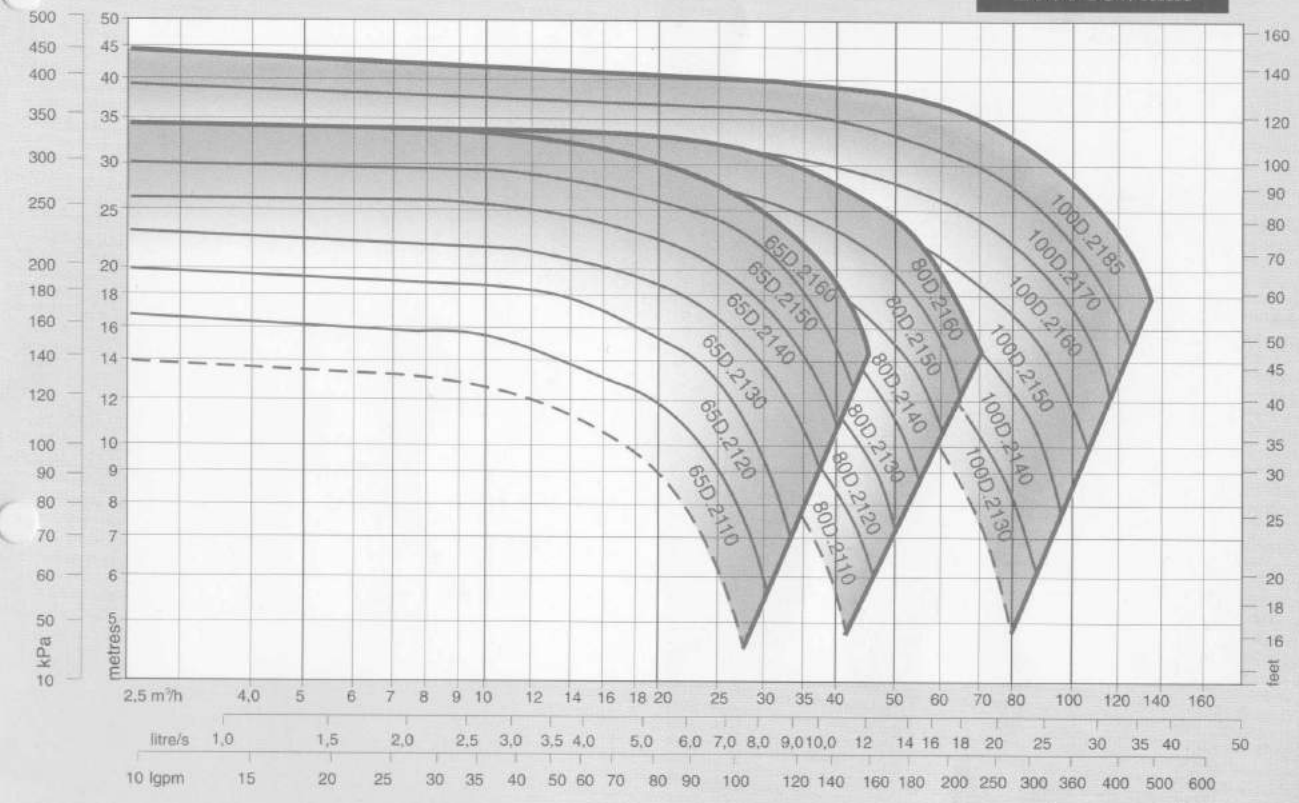

1450 rev/min

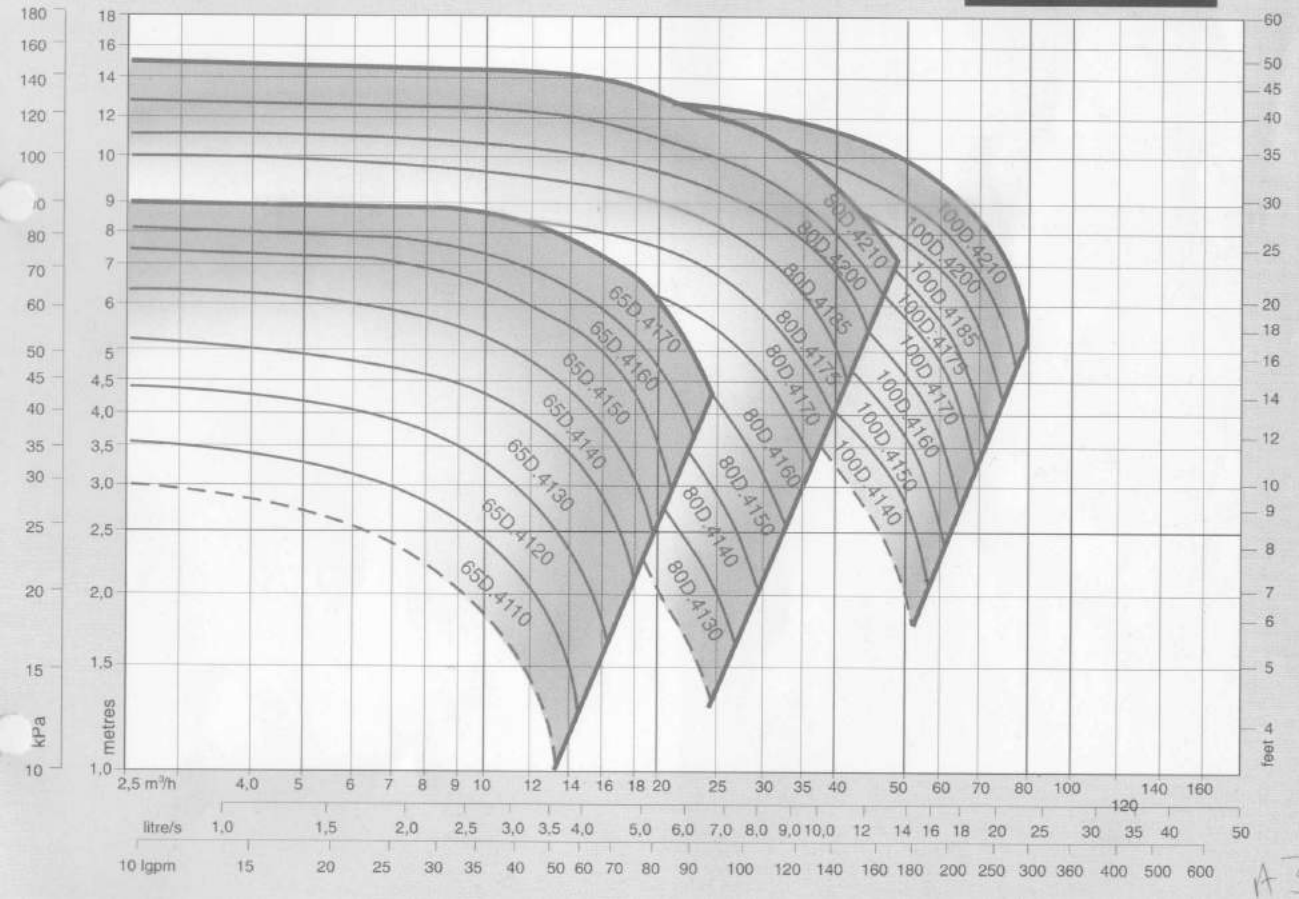

A3

Myson SG Pumps

Technical Information Section

CONTENTS

	<i>Page</i>
<i>Specification:</i> SG Single Pumps	10
<i>Technical Data:</i> SG 50-2 Pole SG 65-2 Pole	11
<i>Technical Data:</i> SG 80-2 Pole SG 100-2 Pole	16
<i>Technical Data:</i> SG 50-4 Pole SG 65-4 Pole	23
<i>Technical Data:</i> SG 80-4 Pole SG 100-4 Pole	28
<i>Technical Data:</i> SG 125-4 Pole SG 150-4 Pole SG 200-4 Pole	37
<i>Technical Data:</i> SG 125-6 Pole SG 150-6 Pole SG 200-6 Pole	42
<i>Specification:</i> SG Twin Pumps	46
<i>Technical Data:</i> SG 65D-2 Pole SG 80D-2 Pole SG 100D-2 Pole	47
<i>Technical Data:</i> SG 65D-4 Pole SG 80D-4 Pole SG 100D-4 Pole	51

SPECIFICATION: SG SINGLE PUMPS

GENERAL SPECIFICATIONS

Application	The circulation, transfer and booster applications of commercial chilled and hot water systems.
Standards	The SG range conforms to (M and E) No.3 - from the Department of the Environment.
Working Pressure	10 bar (1000 KPa) maximum.
Test Pressure	15 bar (1500 Kpa).
Liquid Temperature	-10°C to 120°C (14° to 248°F)
Ambient Temperature	40°C (104°F) maximum. Motors available for ambient temperatures above 40°C on request.
Mechanical Seal	Crane Type 2 or Sealol Type 43 carbon face/ceramic seat. Seal dimensions stated for each pump under individual "Technical Data" sections. For applications at high temperature or for fluids other than water further grades of seal are available on request.
Pipe Flanges	British Standard 4504 NP 10 & NP 16 (DIN 2532 and 2533) flanges are recommended. The slotted flanges on all SG pumps permit the use of counter-flanges to BS10 Tables D and E, BS 4504 NP 6 (DIN 2531) and ASA & SMS standards.
Impeller	High performance cast iron impeller producing low NPSH fitted as standard.
Wear Ring	Bronze impeller option available on all models. Bronze construction resisting corrosion jamming.
Base Plate	Optional extra.
Material	Casing*, Housing & Impeller: Cast Iron to BS 1452 Grade 14 (*SG 200 range casings SG iron) (All bronze construction available on request). Stub shaft: Stainless Steel to BS 970 S431. Casing Sealing Ring: Fibre construction to BS 2815 Grade B. Nuts, bolts, washers & studs: to BS 4190/ISO Metric.

MOTOR DETAILS

General	Totally enclosed fan cooled (TEFC) 3 phase induction motors, Constructed to IP54 with Class B insulation.
Dimensions/Performance	To BS 4999, IEC 72 & DIN 42677.
Frequency	50 Hz.
Terminal Box Protection	IP 54
Bearings	Metric - rated for 40000 hour life.
Rotation	Clockwise from above.
Poles/Speeds	Refer to "Technical Data" Section.

INSTALLATION & SPECIAL ARRANGEMENTS

Mounting Pump can be inserted into the pipeline as shown. The pipework should be rigidly fixed as close as possible to the pump.



Baseplate Available for rigid bolting to a foundation or with anti-vibration mountings.
Pressure Tappings 1/8th BSP (1/8 in) available on request.

TECHNICAL DATA

SG 50-2 Pole
SG 65-2 Pole
2900 rev/min

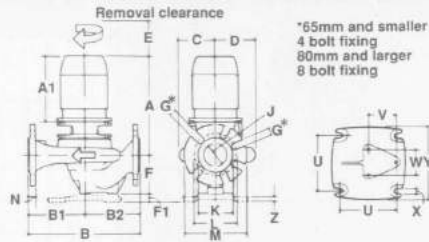
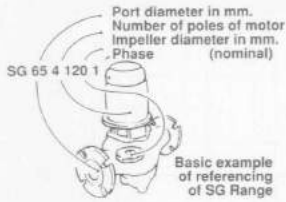

DIMENSIONS (mm) and WEIGHTS (kg)

SG 50-2 Pole

SG 65-2 Pole

	Pump body and motor											Flange						Baseplate							
	A	A1	B	B1	B2	C	D	E	F	F1		G	J	K	L	M	N	kg	U	V	W	X	Y	Z	kg
50-2130	380	255															36								
50-2120	355	230	280	128	152	100	100	100	90	25							32								
50-2110	355	230										4x18	50	90	110	165	17	32	160	80	75	14	214	17	3.1
50-2100	335	210															30								
50-2090	305	205	280	128	152	92	100	100	90	25							28								
50-2080	305	205															28								
65-2210	690	475				175	175										146								
65-2200	690	475	400	200	200	175	175										146								
65-2185	555	400				150	150										98								
65-2175	555	400				150	150										91	225	80	75	18	300	17	7.9	
65-2170	555	400				150	150										89								
65-2160	555	400	360	180	180	150	150										89								
65-2150	480	350				125	126	100	115	25		4X18	65	105	125	185	22	69							
65-2140	480	350				125	126										69								
65-2130	455	325				125	125										49								
65-2120	405	280				100	110										40	160	80	75	14	214	17	3.1	
65-2110	380	255	320	160	160	100	110										37								
65-2100	355	230				100	110										29								
65-2090	355	230				100	110										27								

MOTOR and SEAL DETAILS

SG 50-2 Pole

SG 65-2 Pole

	Frame Size IEC	Shaft Power kW	Speed rev/min	Full Load Current				Start Current Ratio %	Efficiency %	Power Factor	Seal Size mm
				at 500v A	at 415v A	at 380v A	at 220v A				
50-2130	90S	1.5	2845	2.6	3.2	3.5	6.0	580	78.0	0.84	18
50-2120	80B	1.1	2820	1.86	2.24	2.45	4.25	580	77.0	0.88	18
50-2110	80B	1.1	2820	1.86	2.24	2.45	4.25	580	77.0	0.88	18
50-2100	80A	0.75	2820	1.38	1.66	1.81	3.1	500	74.0	0.86	18
50-2090	71B	0.55	2810	1.04	1.25	1.37	2.37	440	72.0	0.85	13
50-2080	71B	0.55	2810	1.04	1.25	1.37	2.37	440	72.0	0.85	13
65-2210	160MA	11	2940	16.3	19.7	21.5	37.1	660	87.5	0.89	38
65-2200	160MA	11	2940	16.3	19.7	21.5	37.1	660	87.5	0.89	38
65-2185	132SB	7.5	2920	11.2	13.5	14.7	25.4	750	88.0	0.88	24
65-2175	132SA	5.5	2920	8.5	10.3	11.2	19.3	720	85.5	0.87	24
65-2170	132SA	5.5	2920	8.5	10.3	11.2	19.3	720	85.5	0.87	24
65-2160	132SA	5.5	2920	8.5	10.3	11.2	19.3	720	85.5	0.87	24
65-2150	112M	4.0	2900	6.2	7.5	8.2	14.2	700	85.0	0.87	24
65-2140	112M	4.0	2900	6.2	7.5	8.2	14.2	700	85.0	0.87	24
65-2130	100L	3.0	2880	4.9	5.9	6.4	11.1	700	82.0	0.87	24
65-2120	90L	2.2	2860	3.6	4.4	4.8	8.3	650	82.0	0.85	18
65-2110	90S	1.5	2845	2.6	3.2	3.5	6.0	580	78.0	0.84	18
65-2100	80B	1.1	2820	1.86	2.24	2.45	4.25	580	77.0	0.88	18
65-2090	80A	0.75	2820	1.36	1.64	1.81	3.1	500	74.0	0.86	18

STAR/DELTA STARTING

For suitability with Star/Delta Starting please refer to relevant motor frame size.

Frames 71-100: - Suitable (as standard) for dual voltage supplies and should be connected in Star for high voltages (eg 380-415v) or Delta for lower voltages (eg 220v).

- May be started Star/ Delta if used on low voltage supplies.

Frames 112-180: - Suitable (as standard) for Direct on Line (Delta Connection) or Star/Delta starting.

SG 50-2 Pole

2900 rev/min

- Impeller sizes up to 130mm -
50 Hz / 20°C

Performance

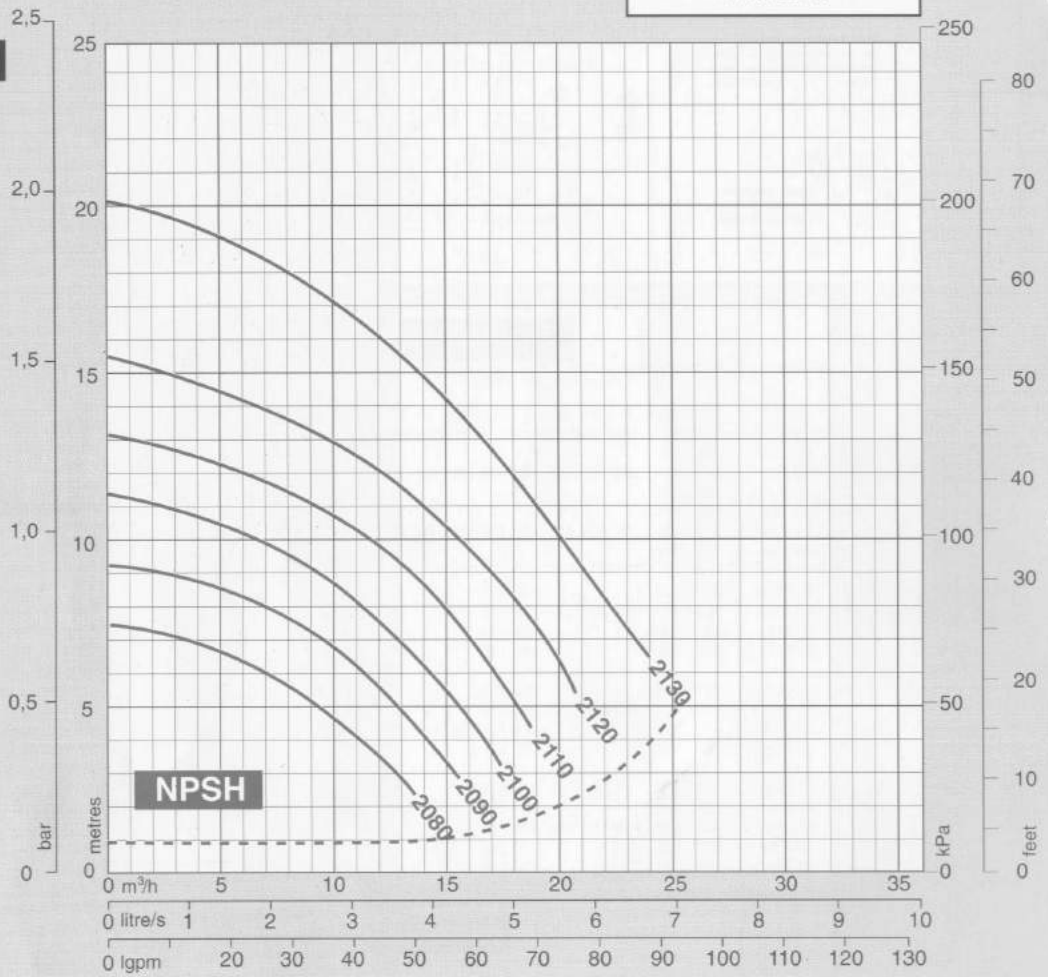

Pump Efficiency

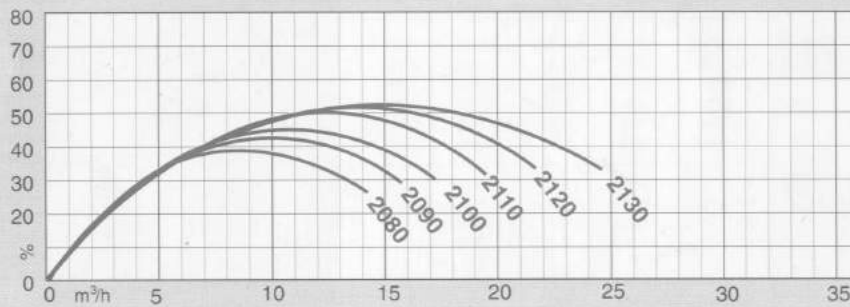

Motor Output

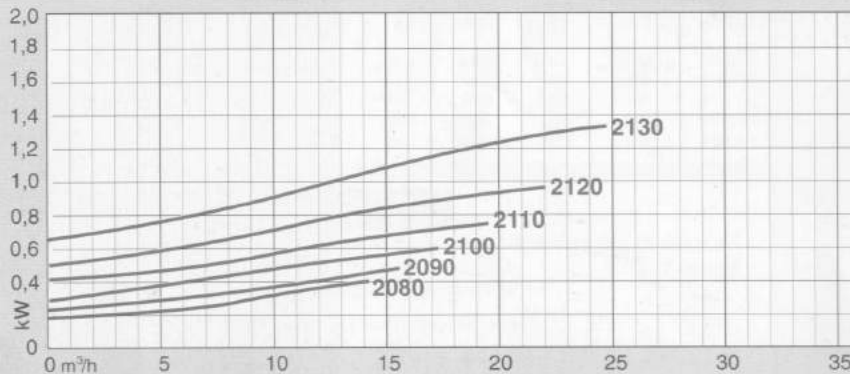

SG 65-2 Pole

2900 rev/min

- Impeller sizes up to 130mm -
50 Hz / 20°C

Performance

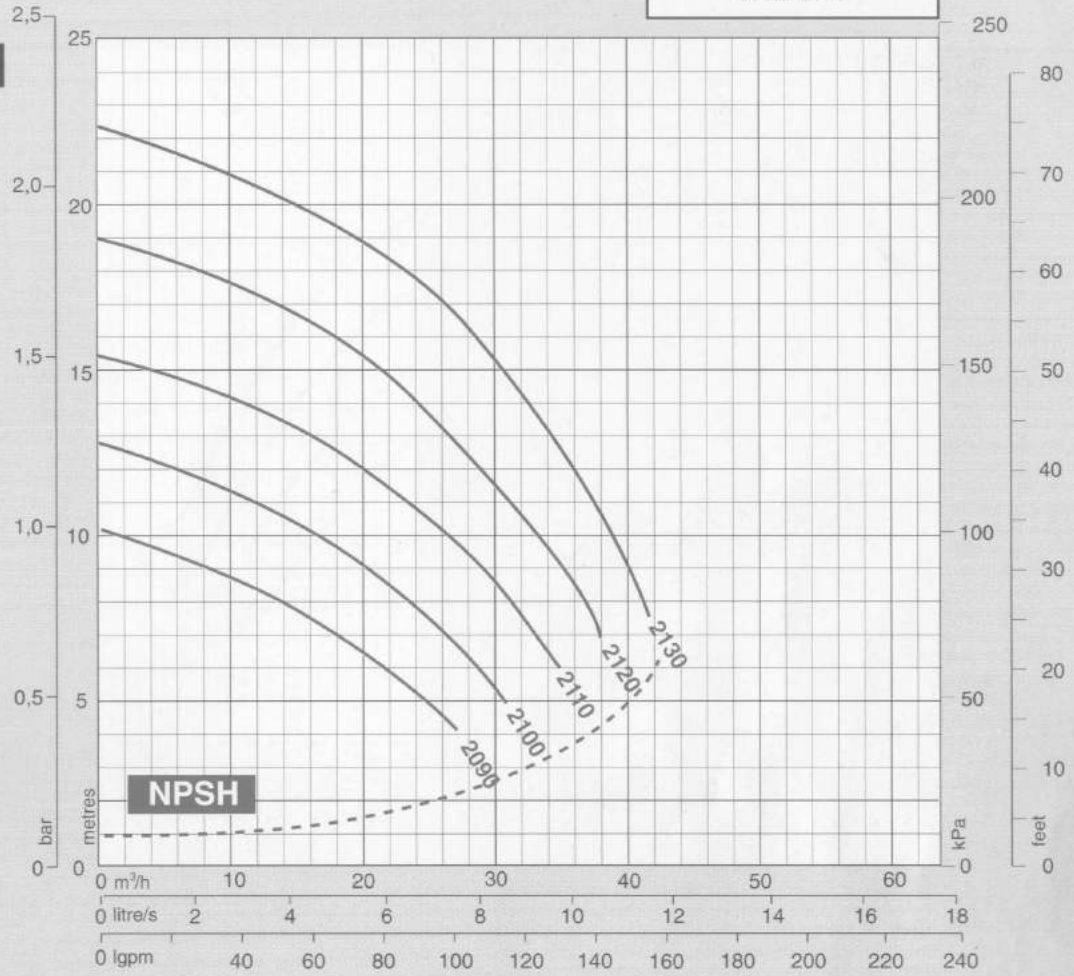

Pump Efficiency

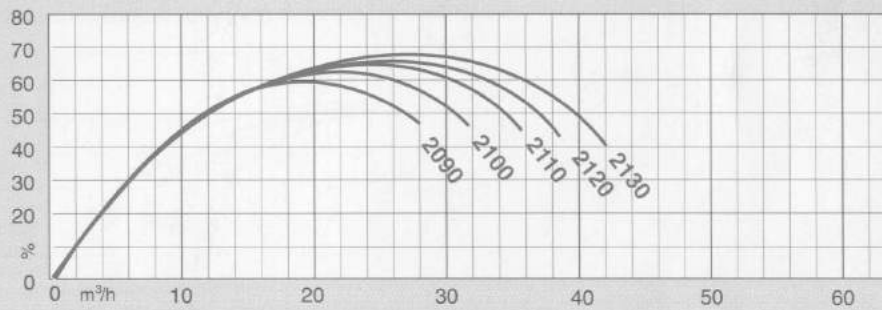

Motor Output

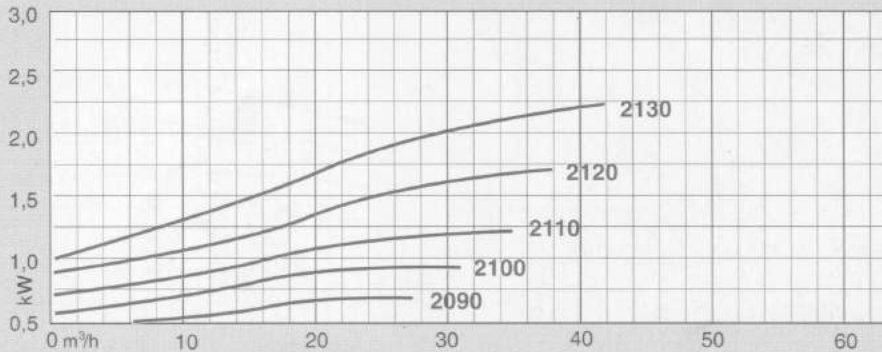

SG 65-2 Pole

2900 rev/min

- Impeller sizes up to 170mm -
50 Hz / 20°C -

Performance

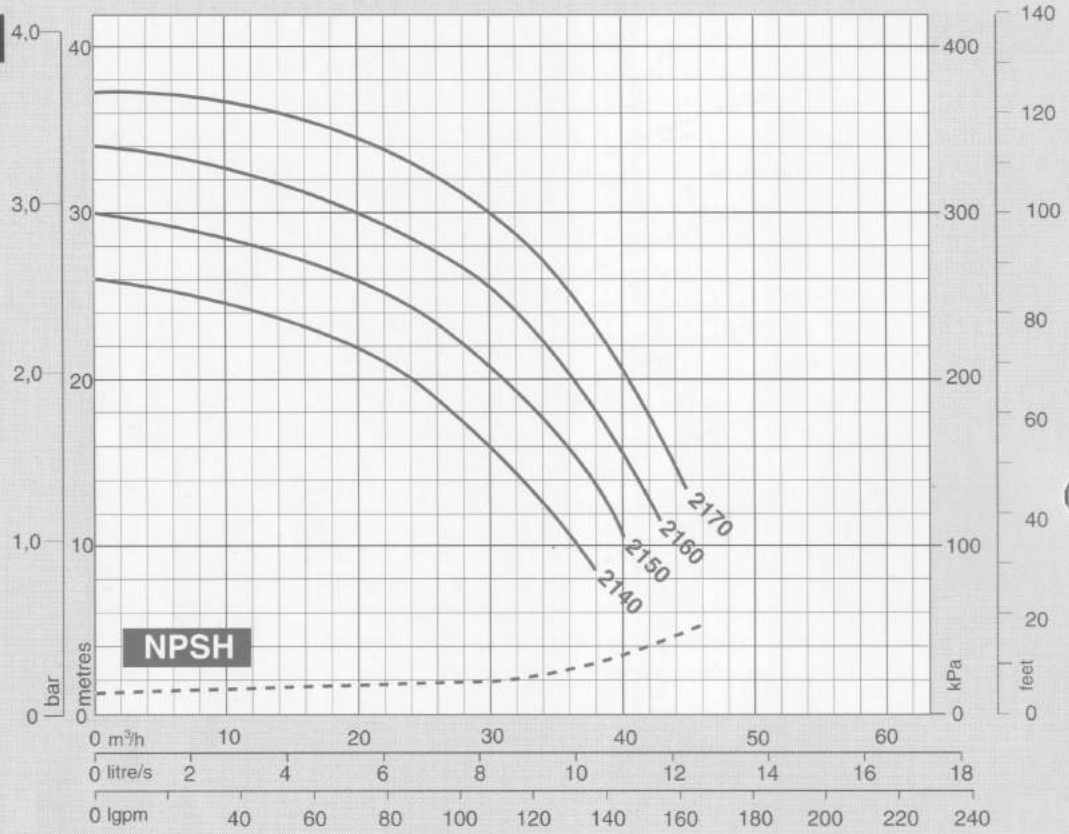

Pump Efficiency

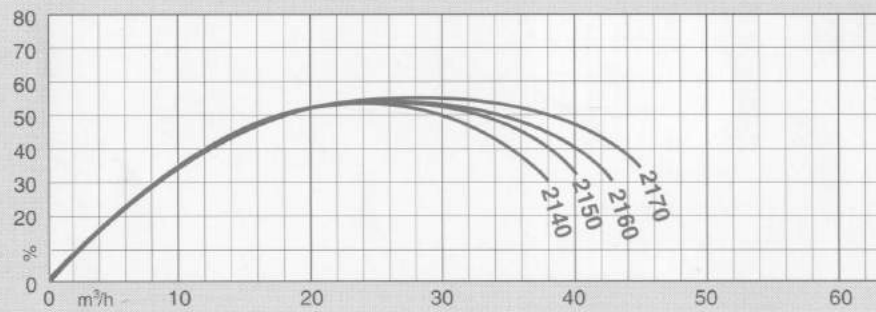

Motor Output

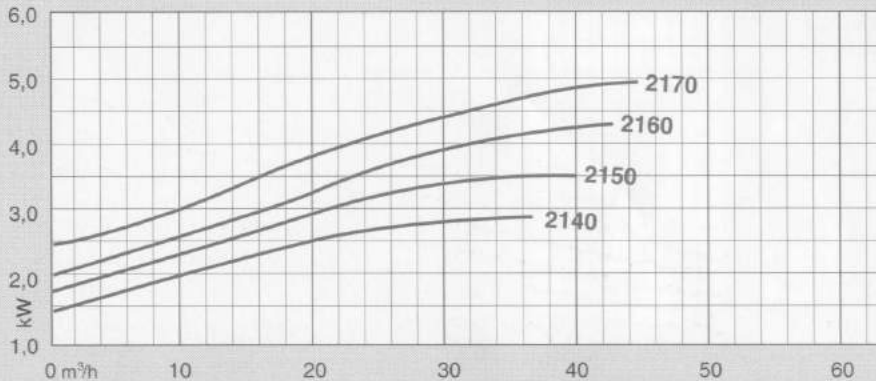

SG 65-2 Pole

2900 rev/min

- Impeller sizes up to 210mm -
50 Hz / 20°C

Performance

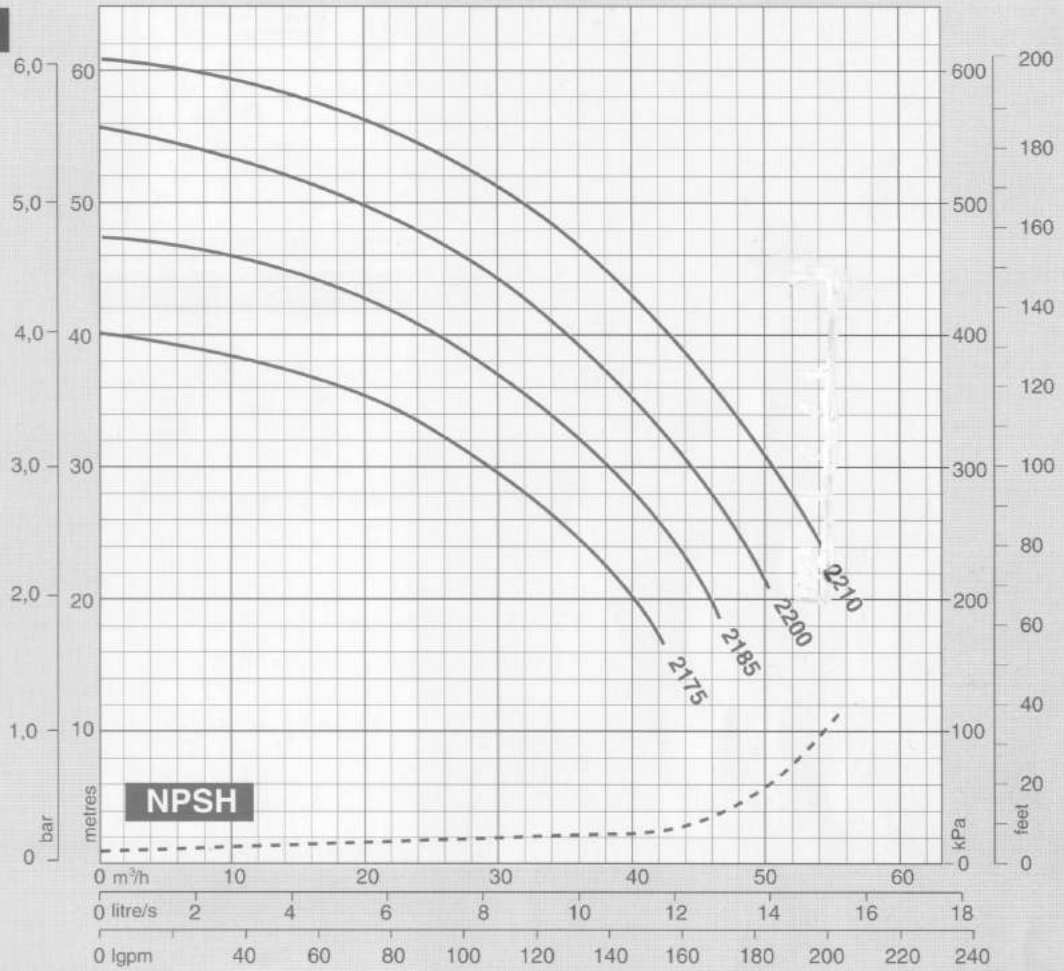

Pump Efficiency

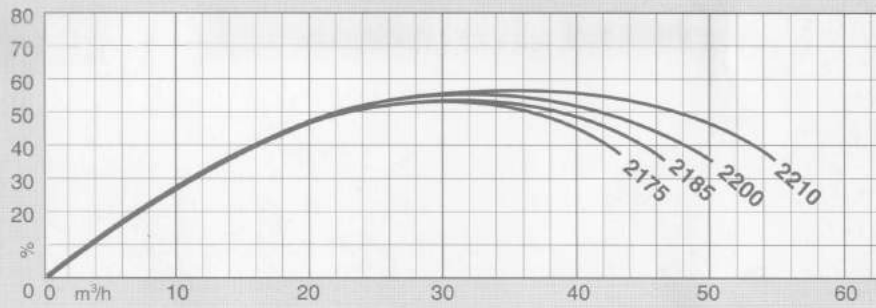

Motor Output

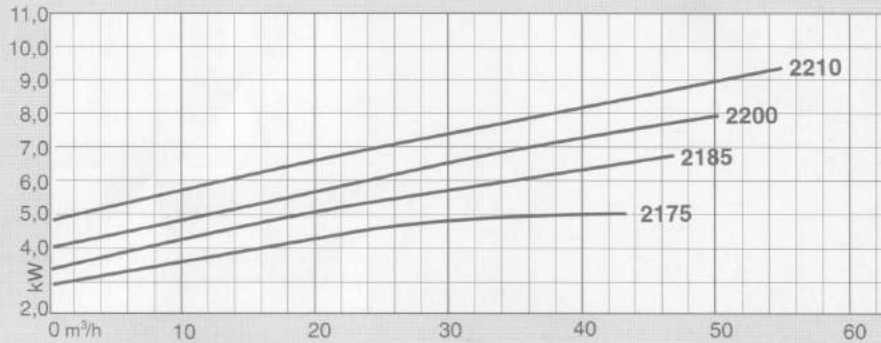

TECHNICAL DATA

SG 80-2 Pole
SG 100-2 Pole
2900 rev/min

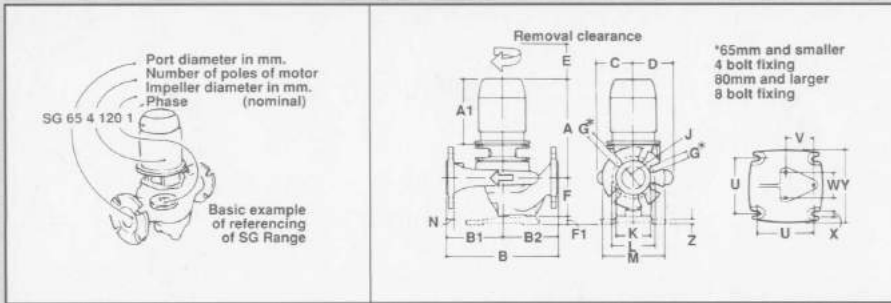

DIMENSIONS (mm) and WEIGHTS (kg)

	Pump body and motor											Flange						Baseplate						
	A	A1	B	B1	B2	C	D	E	F	F1	G	J	K	L	M	N	kg	U	V	W	X	Y	Z	kg
SG 80-2 Pole	80-2210	690	475														167							
	80-2200	690	475														167							
	80-2185	690	475	450	225	225	175	175									151	225	80	75	18	300	17	7.9
	80-2175	690	475														151							
	80-2170	555	400														101							
	80-2160	555	400	400	200	200	150	150	125	135	25	8x18	80	120	145	200	24	93						
	80-2150	555	400														93							
	80-2130	480	350				125	125									70							
	80-2120	455	325	360	180	180	125	125									54	160	80	75	14	214	17	3.1
	80-2110	405	280				103	125									45							
80-2100	380	255														42								
80-2090	355	230	360	180	180	103	125									38								
SG 100-2 Pole	100-2205	760	545			180	180									275								
	100-2200	735	520	500	250	250	175	175								222								
	100-2185	690	475				175	175								176	225	112.5	125	18	300	17	7.9	
	100-2170	690	475				175	175								154								
	100-2160	690	475	450	225	225	175	175	125	155	25	8x18	100	150	178	230	24	154						
	100-2145	555	400				150	159								107								
	100-2130	555	400				150	150								98								
	100-2120	555	400	450	225	225	150	150								98								
	100-2110	480	350				125	147								78								

MOTOR and SEAL DETAILS

	Frame Size IEC	Shaft Power kW	Speed rev/min	Full Load Current at				Start Current Ratio %	Efficiency %	Power Factor	Seal Size mm	
				at 500v A	at 415v A	at 380v A	at 220v A					
SG 80-2 Pole	80-2210	160MB	15.0	2940	21.5	25.9	28.3	48.9	700	89.5	0.90	38
	80-2200	160MB	15.0	2940	21.5	25.9	28.3	48.9	700	89.5	0.90	38
	80-2185	160MA	11.0	2940	16.3	19.7	21.5	37.1	660	87.5	0.89	38
	80-2175	160MA	11.0	2940	16.3	19.7	21.5	37.1	660	87.5	0.89	38
	80-2170	132SB	7.5	2920	11.2	13.5	14.7	25.4	750	88.0	0.88	24
	80-2160	132SA	5.5	2920	8.5	10.3	11.2	19.3	720	85.5	0.87	24
	80-2150	132SA	5.5	2920	8.5	10.3	11.2	19.3	720	85.5	0.87	24
	80-2130	112M	4.0	2900	6.2	7.5	8.2	14.2	700	85.0	0.87	24
	80-2120	100L	3.0	2880	4.9	5.9	6.4	11.1	700	82.0	0.87	24
	80-2110	90L	2.2	2860	3.6	4.4	4.8	8.3	650	82.0	0.85	18
80-2100	90S	1.5	2845	2.6	3.2	3.5	6.0	580	78.0	0.84	18	
80-2090	80B	1.1	2820	1.86	2.24	2.45	4.25	580	77.0	0.88	18	
SG 100-2 Pole	100-2205	180M	22.0	2940	32.5	39.1	42.7	73.8	630	89.0	0.88	38
	100-2200	160L	18.5	2940	26.6	32.0	35.0	60.5	720	89.5	0.90	38
	100-2185	160MB	15.0	2940	21.5	25.9	28.3	48.9	700	89.5	0.90	38
	100-2170	160MA	11.0	2940	16.3	19.7	21.5	37.1	660	87.5	0.89	38
	100-2160	160MA	11.0	2940	16.3	19.7	21.5	37.1	660	87.5	0.89	38
	100-2145	132SB	7.5	2920	11.2	13.5	14.7	25.4	750	88.0	0.88	24
	100-2130	132SA	5.5	2920	8.5	10.3	11.2	19.3	720	85.5	0.87	24
	100-2120	132SA	5.5	2920	8.5	10.3	11.2	19.3	720	85.5	0.87	24
	100-2110	112M	4.0	2900	6.2	7.5	8.2	14.2	700	85.0	0.87	24

STAR/DELTA STARTING

For suitability with Star/Delta Starting please refer to relevant motor frame size.

- Frames 71-100:**
- Suitable (as standard) for dual voltage supplies and should be connected in Star for high voltages (eg 350-415v) or Delta for lower voltages (eg 220v).
 - May be started Star/ Delta if used on low voltage supplies.

- Frames 112-180:**
- Suitable (as standard) for Direct on Line (Delta Connection) or Star/Delta starting.

SG 80-2 Pole

2900 rev/min

- Impeller sizes up to 130mm -
50 Hz / 20°C

Performance

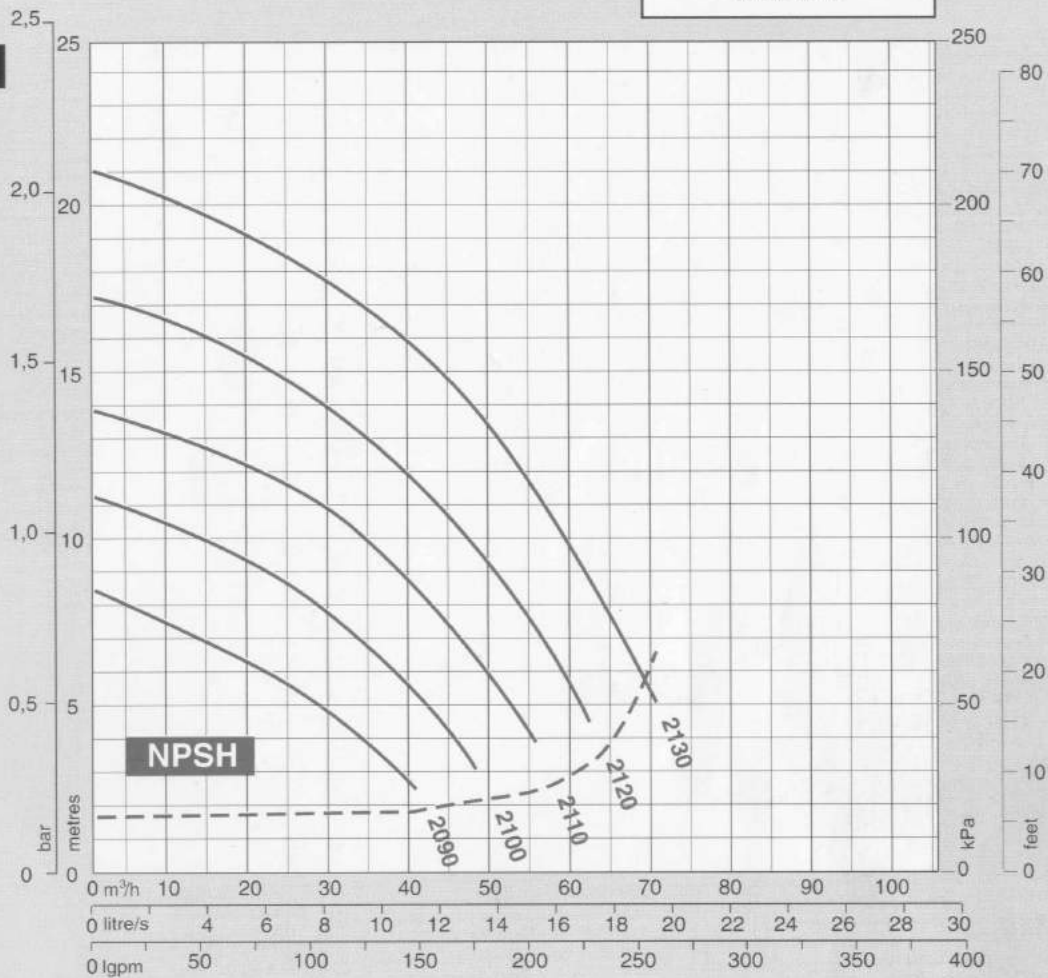

Pump Efficiency

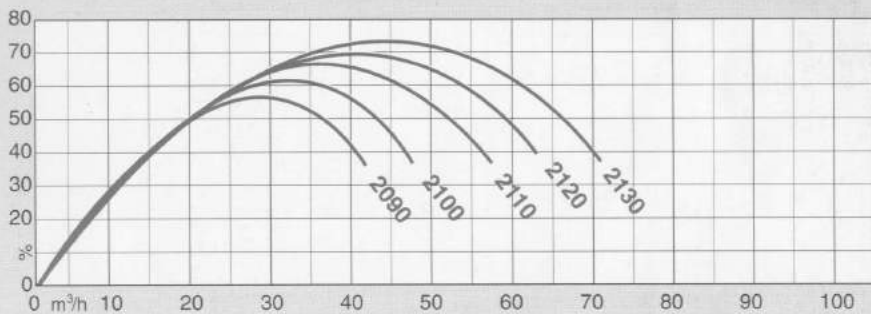

Motor Output

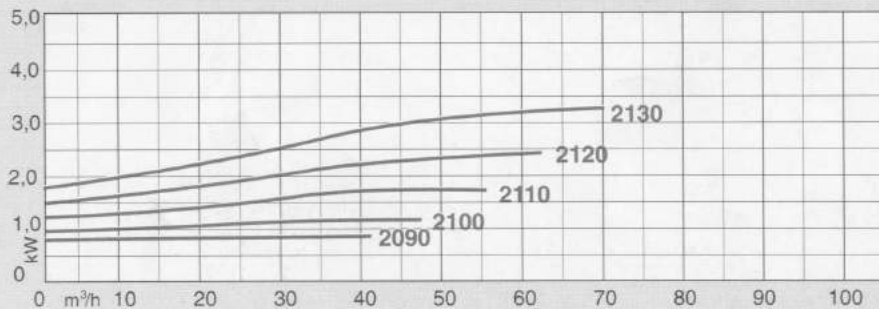

SG 100-2 Pole

2900 rev/min

- Impeller sizes up to 170mm -
50 Hz / 20°C

Performance

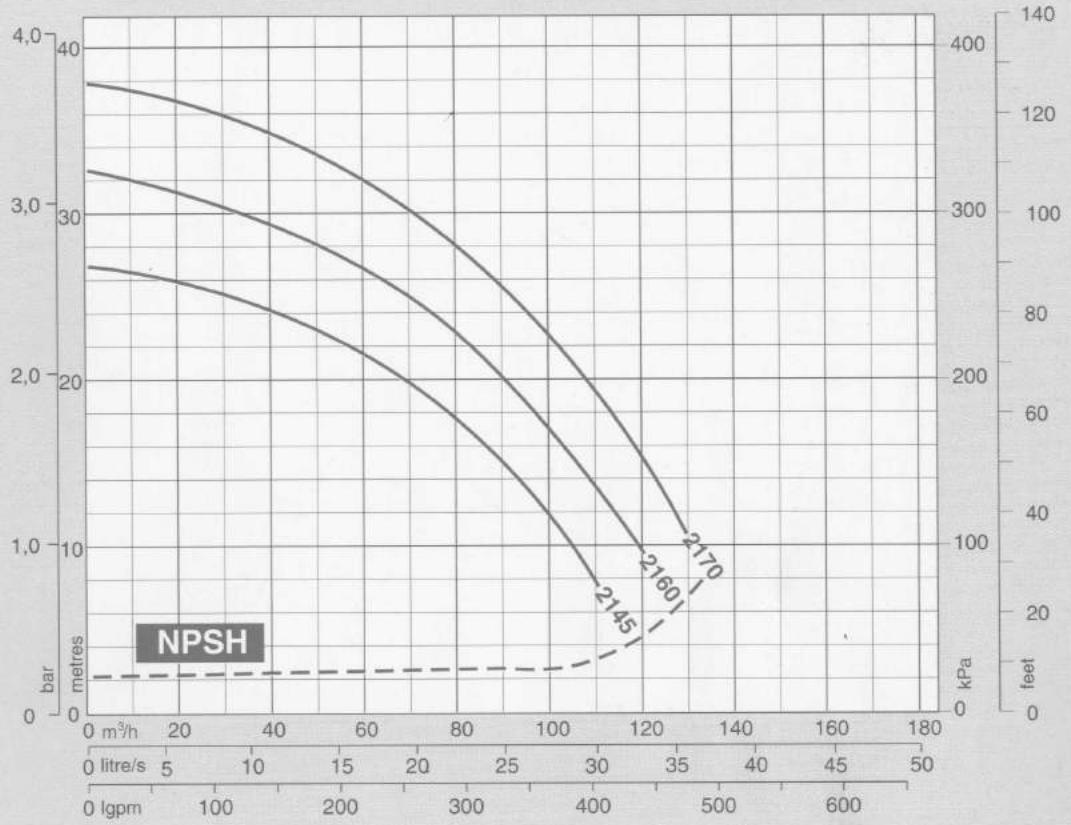

Pump Efficiency

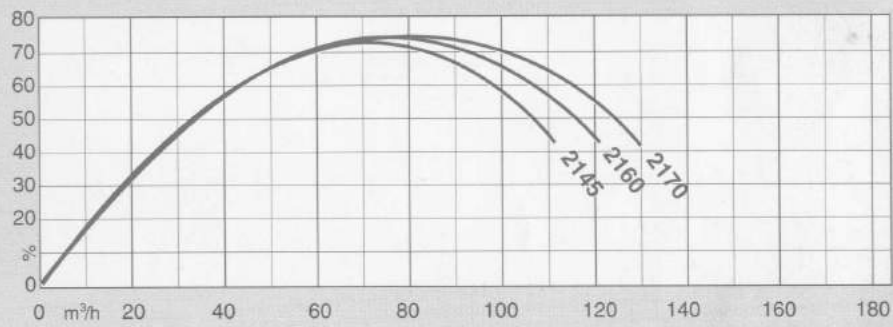

Motor Output

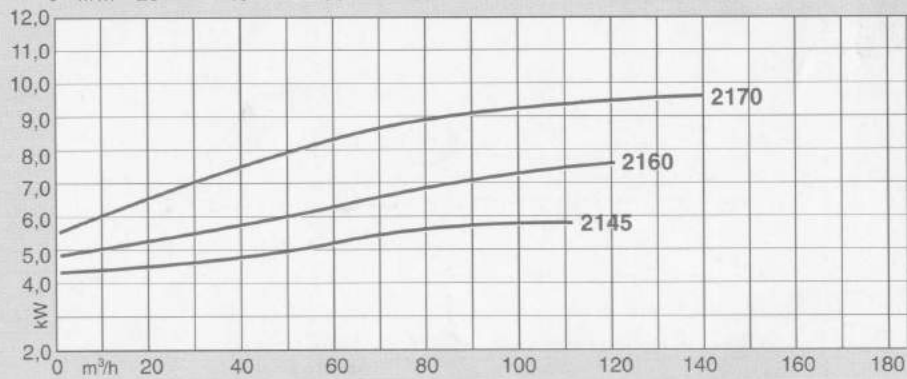

SG 80-2Pole

2900 rev/min

- Impeller sizes up to 170mm -
50 Hz / 20°C

Performance

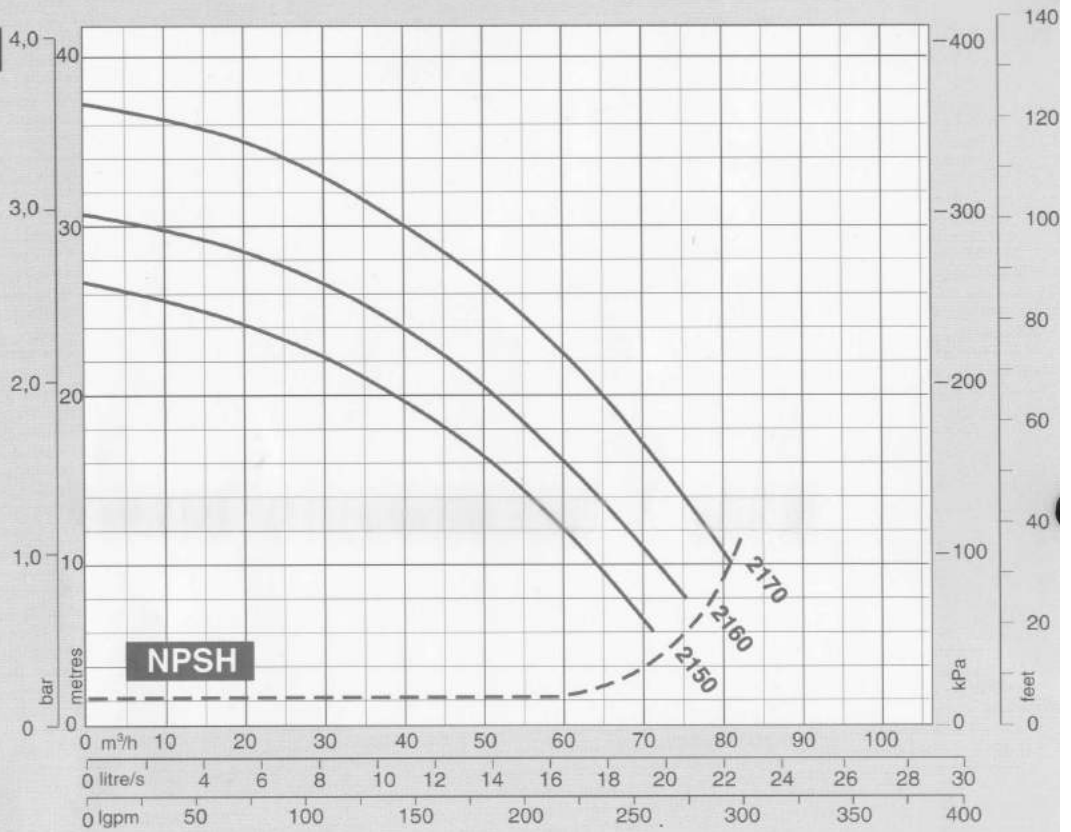

Pump Efficiency

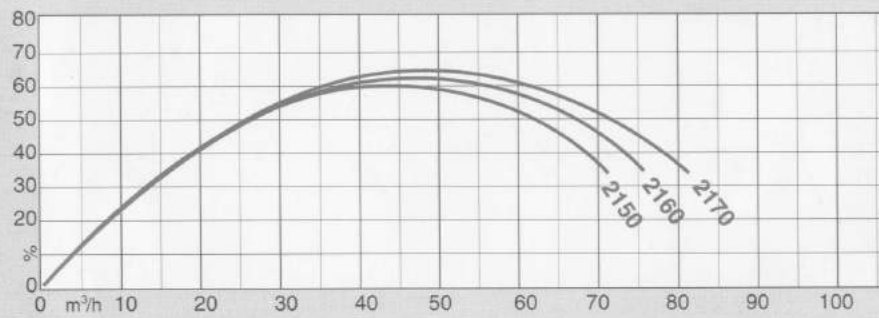

Motor Output

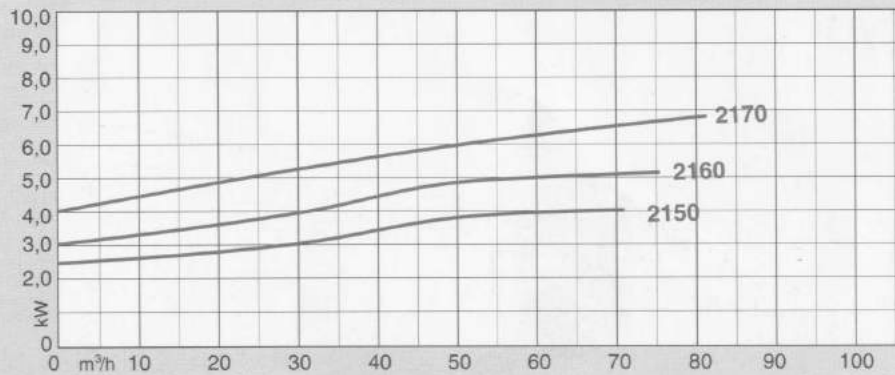

SG 80-2 Pole

2900 rev/min

- Impeller sizes up to 210mm -
50 Hz / 20°C

Performance

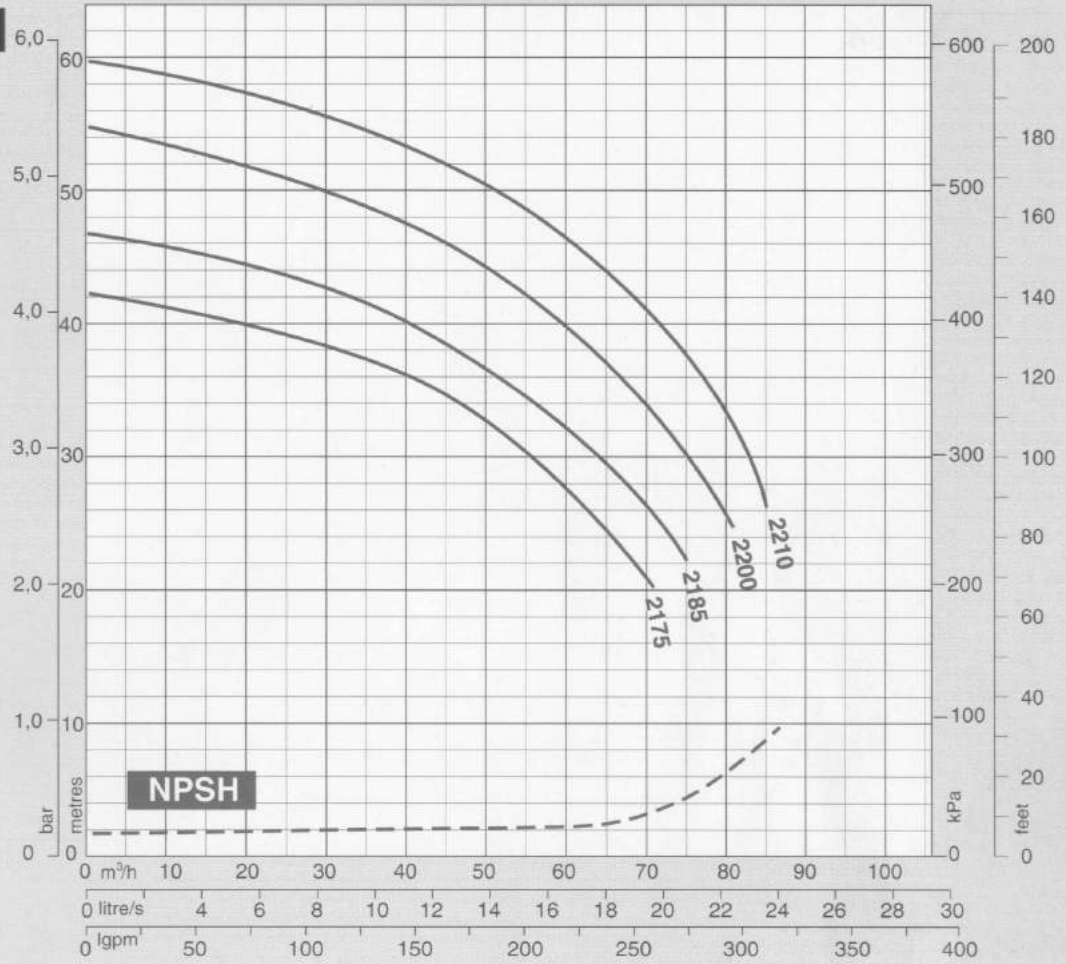

Pump Efficiency

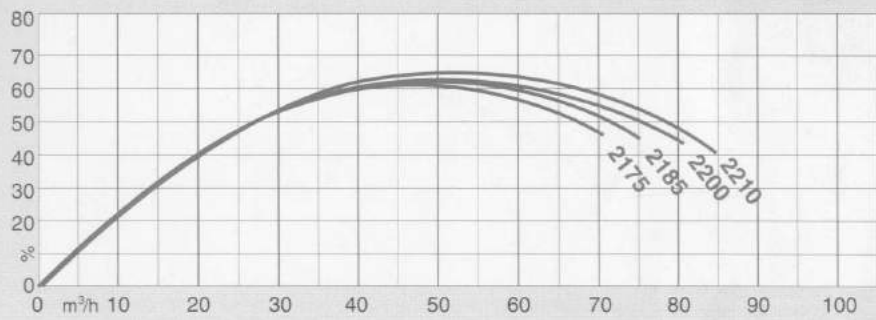

Motor Output

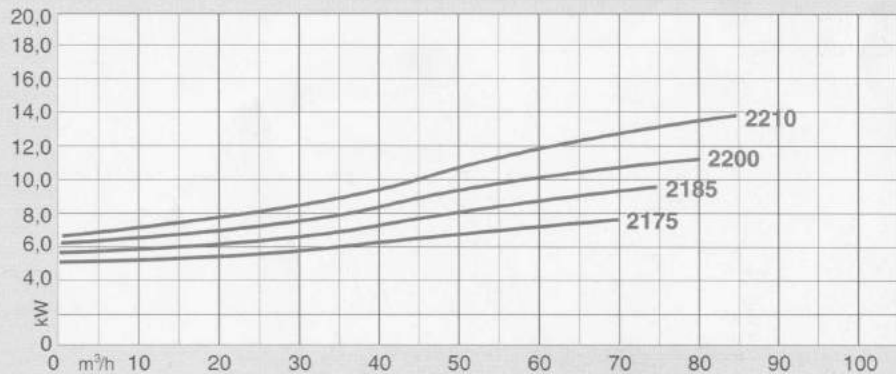

SG 100-2 Pole

2900 rev/min

- Impeller sizes up to 130mm -
50 Hz / 20°C

Performance

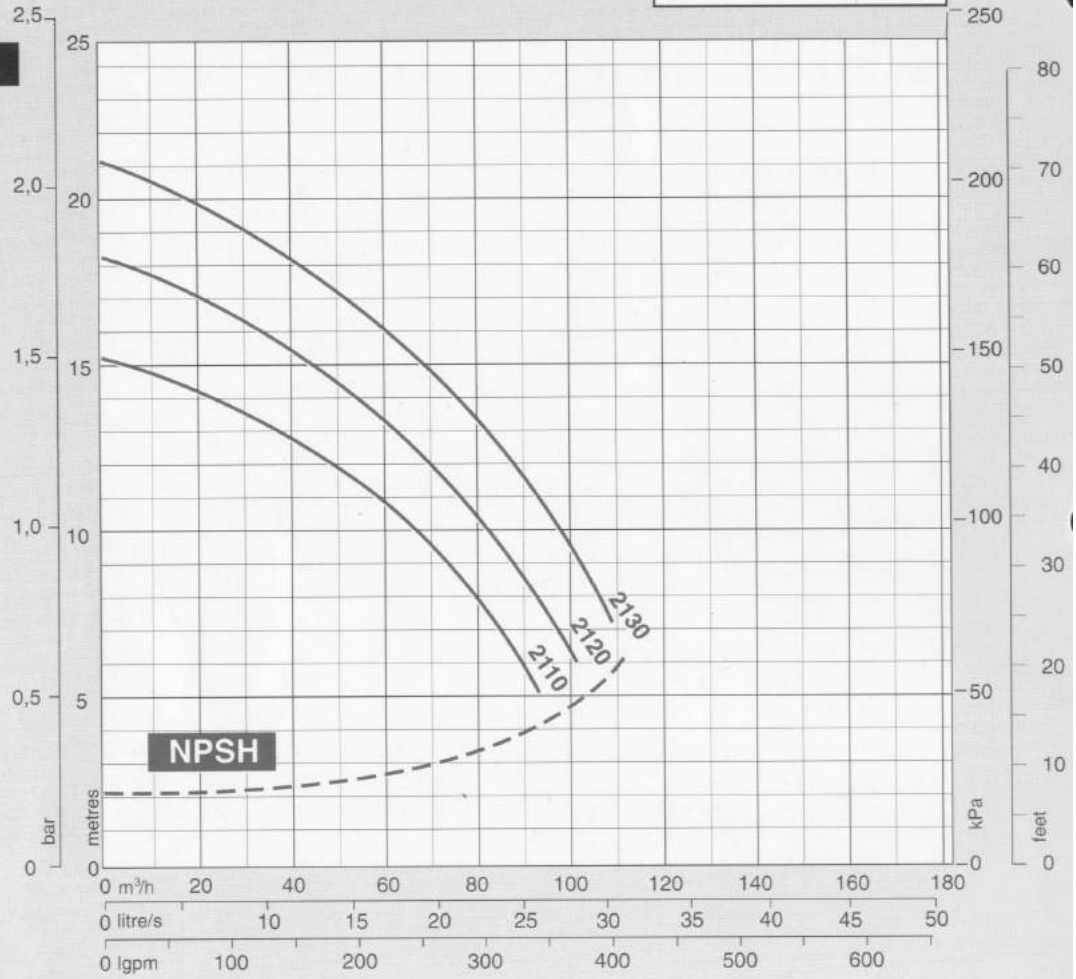

Pump Efficiency

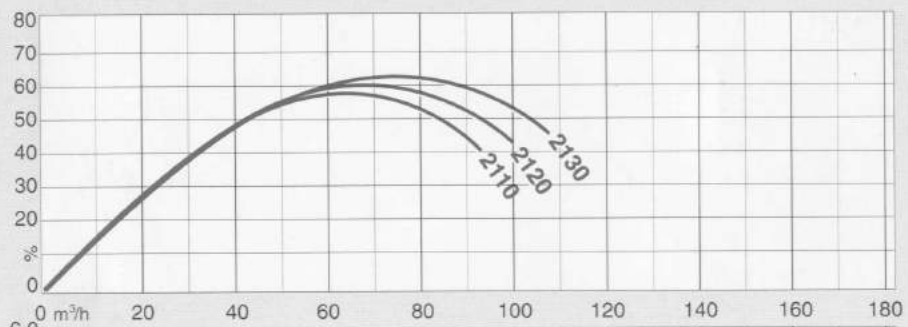

Motor Output

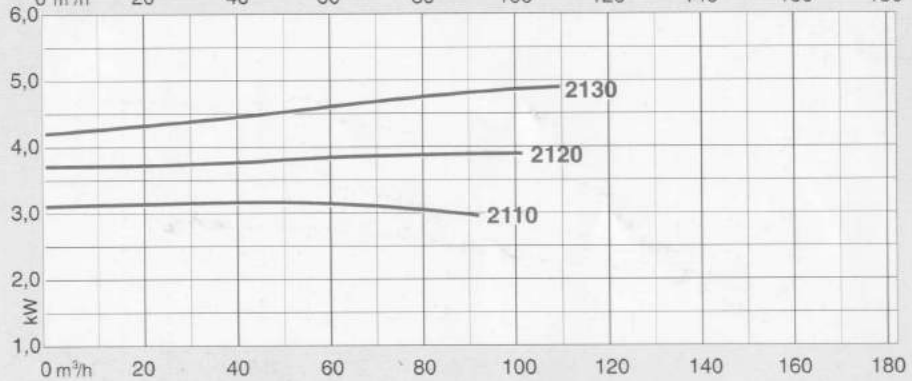

SG 100-2 Pole

2900 rev/min

- Impeller sizes up to 210mm -
50 Hz / 20°C

Performance

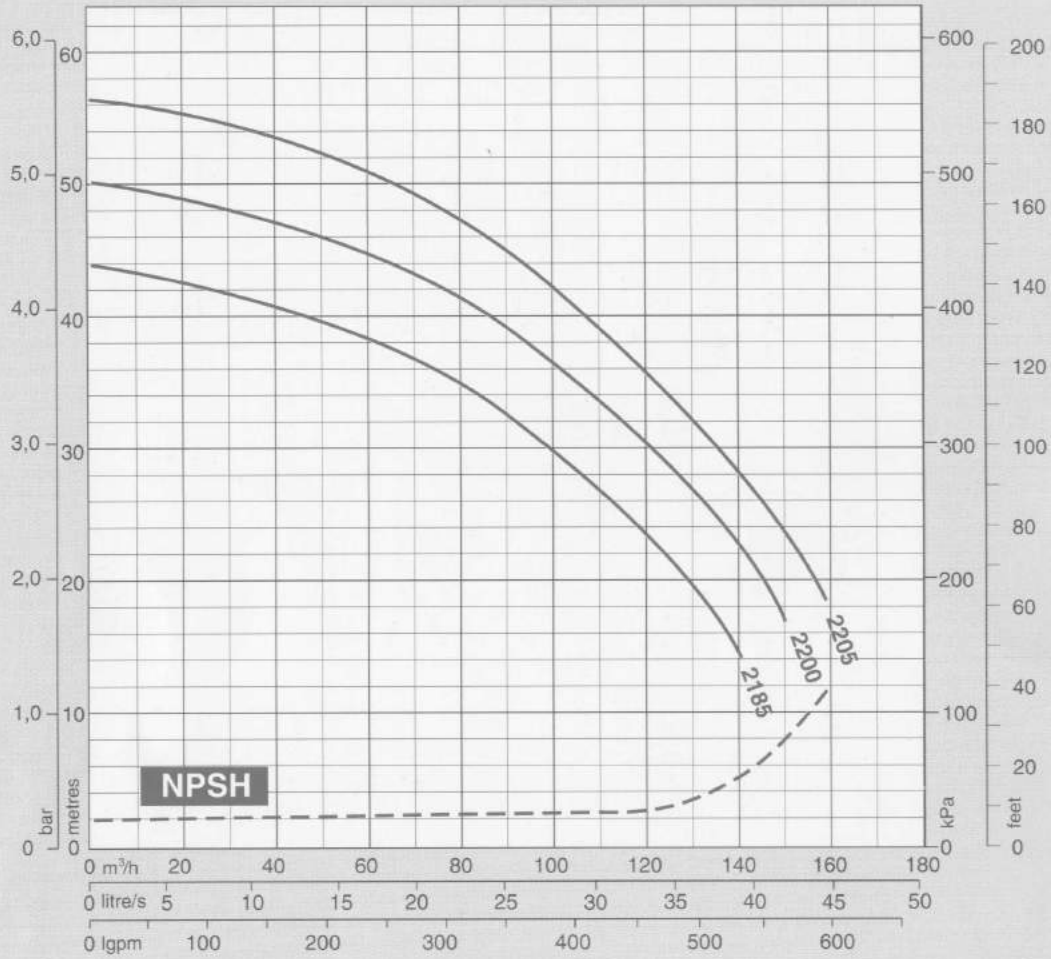

Pump Efficiency

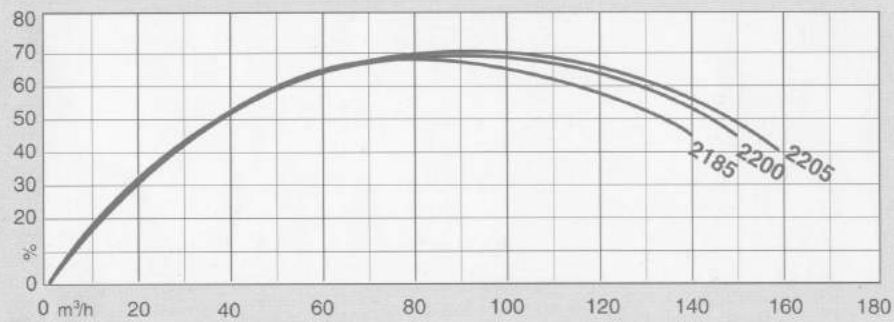

Motor Output

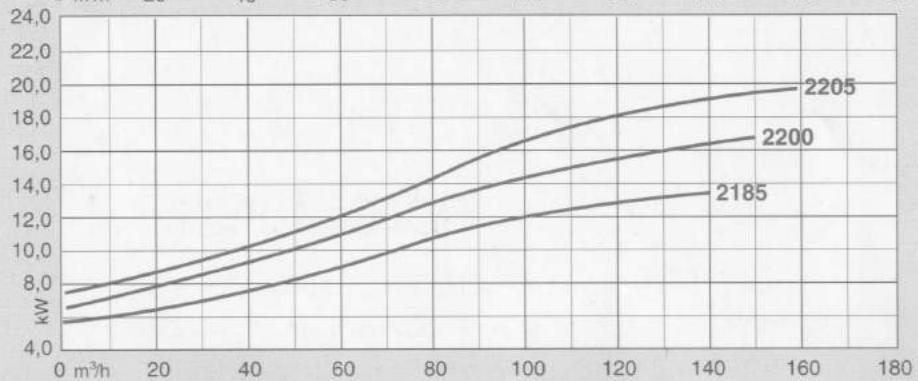

TECHNICAL DATA

SG 50-4 Pole
SG 65-4 Pole
1450 rev/min

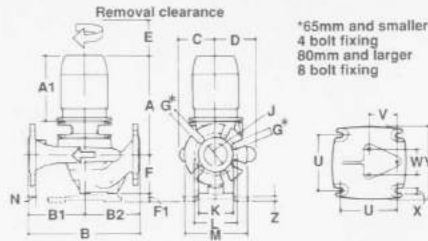
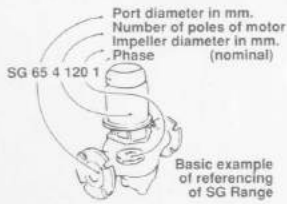

DIMENSIONS (mm) and WEIGHTS (kg)

SG 50-4 Pole

SG 65-4 Pole

	Pump body and motor											Flange					Baseplate							
	A	A1	B	B1	B2	C	D	E	F	F1	G	J	K	L	M	N	kg	U	V	W	X	Y	Z	kg
50-4130	285	185															25							
50-4120	285	185	280	128	152	92	100	100	90	25	4X18.50	90	110	165	17	25		160	80	75	14	214	17	3.1
50-4110	285	185															25							
65-4210	405	280															47							
65-4200	380	255	400	200	200	130	144										44							
65-4180	355	230															39							
65-4170	355	230															37							
65-4160	335	210	360	180	180	113	126	100	115	25	4X18.65	105	125	185	17	34		160	80	75	14	214	17	3.1
65-4150	335	210															34							
65-4140	305	205															32							
65-4130	305	205															28							
65-4120	285	185	320	160	160	94	110										26							
65-4110	285	185															26							

MOTOR and SEAL DETAILS

SG 50-4 Pole

SG 65-4 Pole

	Frame Size IEC	Shaft Power kW	Speed rev/min	Full Load Current				Start Current Ratio %	Efficiency %	Power Factor	Seal Size mm
				at 500v A	at 415v A	at 380v A	at 220v A				
50-4130	71A	0.25	1390	0.61	0.74	0.81	1.4	340	65.0	0.72	13
50-4120	71A	0.25	1390	0.61	0.74	0.81	1.4	340	65.0	0.72	13
50-4110	71A	0.25	1390	0.61	0.74	0.81	1.4	340	65.0	0.72	13
65-4210	90L	1.5	1415	2.8	3.4	3.7	6.5	530	77.0	0.79	18
65-4200	90S	1.1	1415	2.2	2.7	2.9	4.9	470	74.0	0.79	18
65-4180	80B	0.75	1400	1.46	1.76	1.92	3.3	470	76.0	0.78	18
65-4170	80B	0.75	1400	1.46	1.76	1.92	3.3	470	76.0	0.78	18
65-4160	80A	0.55	1400	1.11	1.35	1.47	2.52	440	74.0	0.77	18
65-4150	80A	0.55	1400	1.11	1.35	1.47	2.52	440	74.0	0.77	18
65-4140	71B	0.37	1400	0.87	1.05	1.15	1.98	350	69.0	0.71	13
65-4130	71B	0.37	1400	0.87	1.05	1.15	1.98	350	69.0	0.71	13
65-4120	71A	0.25	1390	0.61	0.74	0.81	1.4	340	65.0	0.72	13
65-4110	71A	0.25	1390	0.61	0.74	0.81	1.4	340	65.0	0.72	13

STAR/DELTA STARTING

For suitability with Star/Delta Starting please refer to relevant motor frame size.

Frames 71-100: - Suitable (as standard) for dual voltage supplies and should be connected in Star for high voltages (eg 380-415v) or Delta for lower voltages (eg 220v).

- May be started Star/ Delta if used on low voltage supplies.

Frames 112-180: - Suitable (as standard) for Direct on Line (Delta Connection) or Star/Delta starting.

SG 50-4 Pole
1450 rev/min
 - Impeller sizes up to 130mm -
 50 Hz / 20°C

Performance

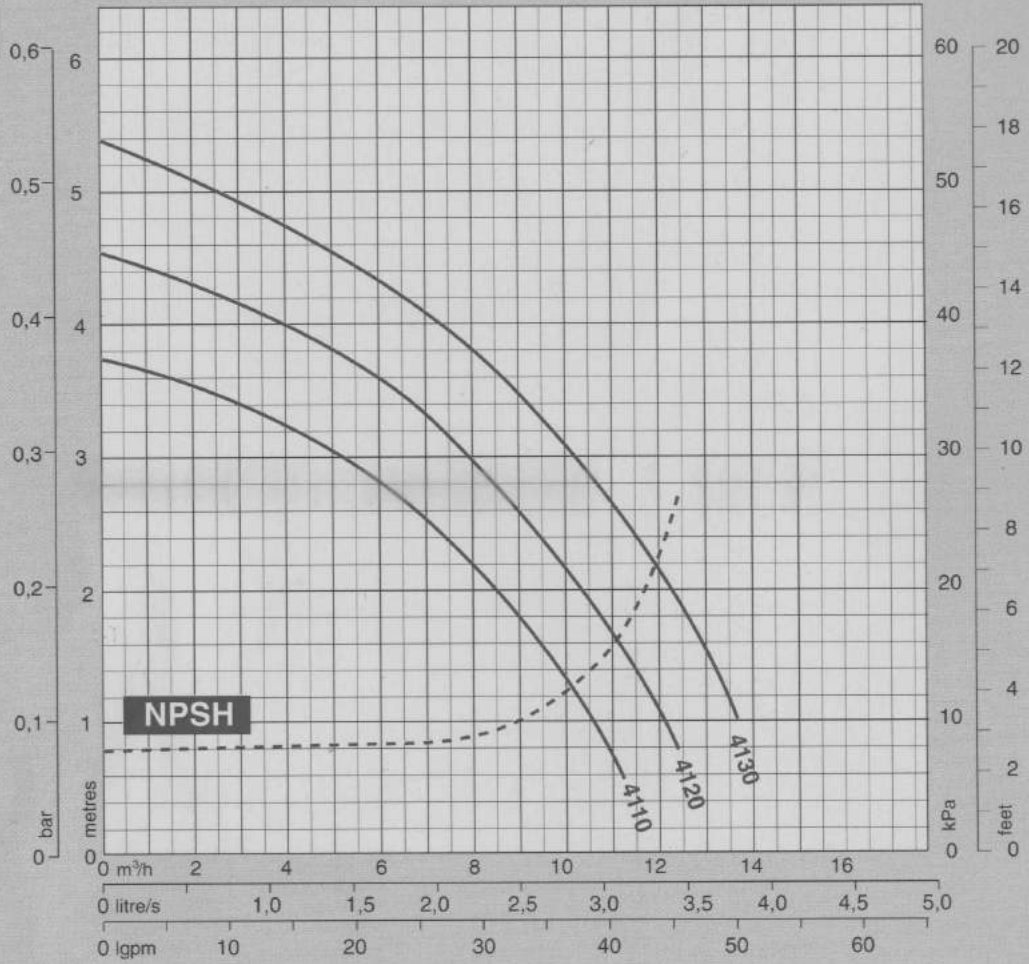

Pump Efficiency

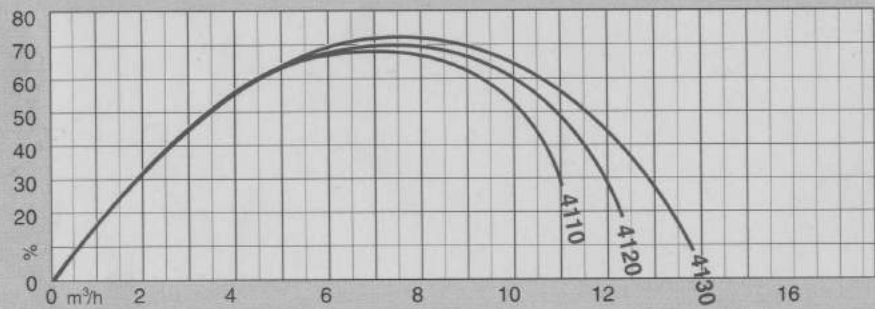

Motor Output

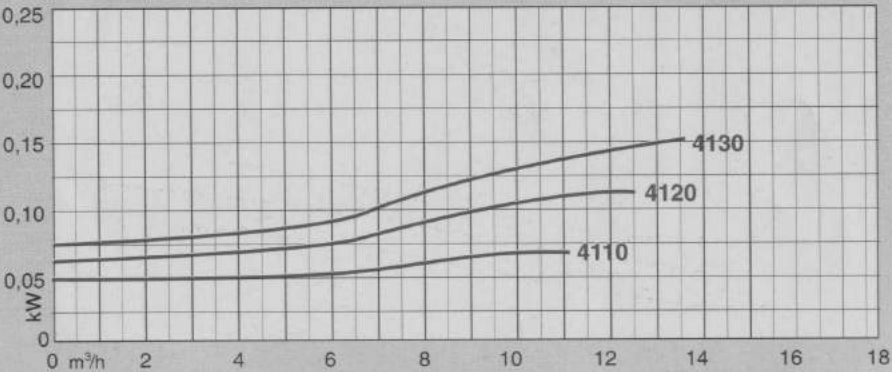

SG 65-4 Pole
1450 rev/min
 - Impeller sizes up to 130mm -
 50 Hz / 20°C

Performance

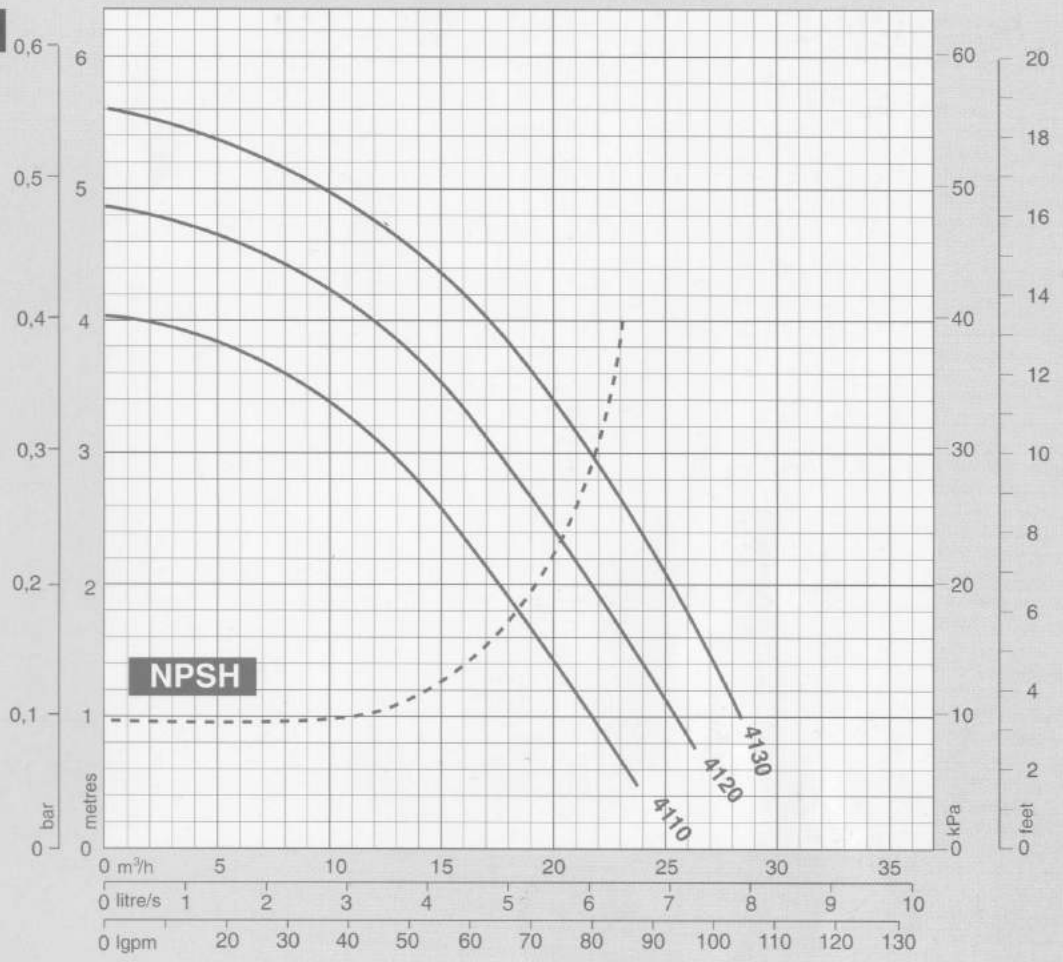

Pump Efficiency

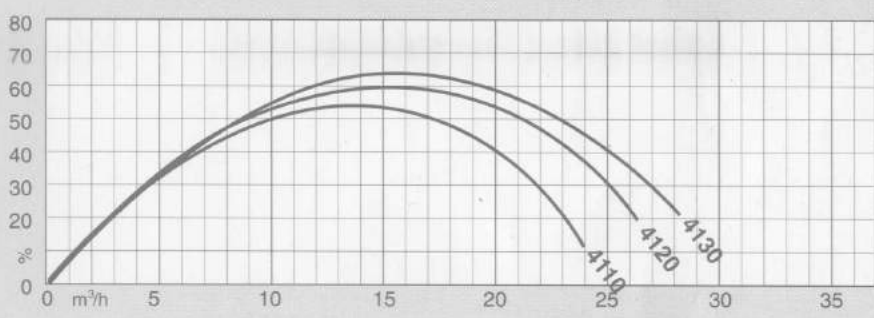

Motor Output

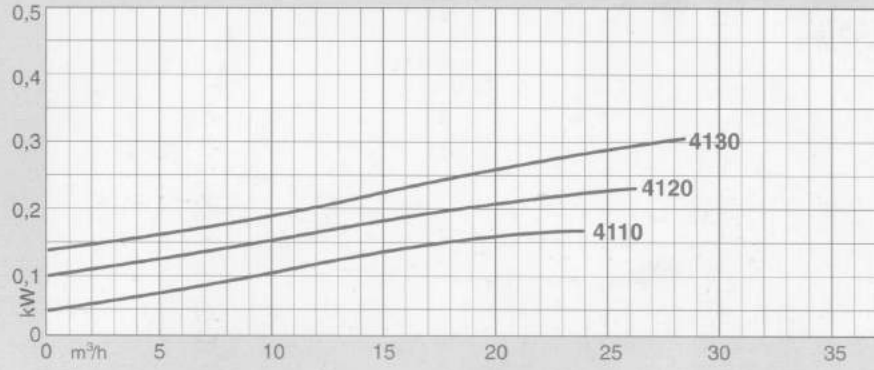

SG 65-4 Pole
1450 rev/min
 - Impeller sizes up to 170mm -
 50 Hz / 20°C

Performance

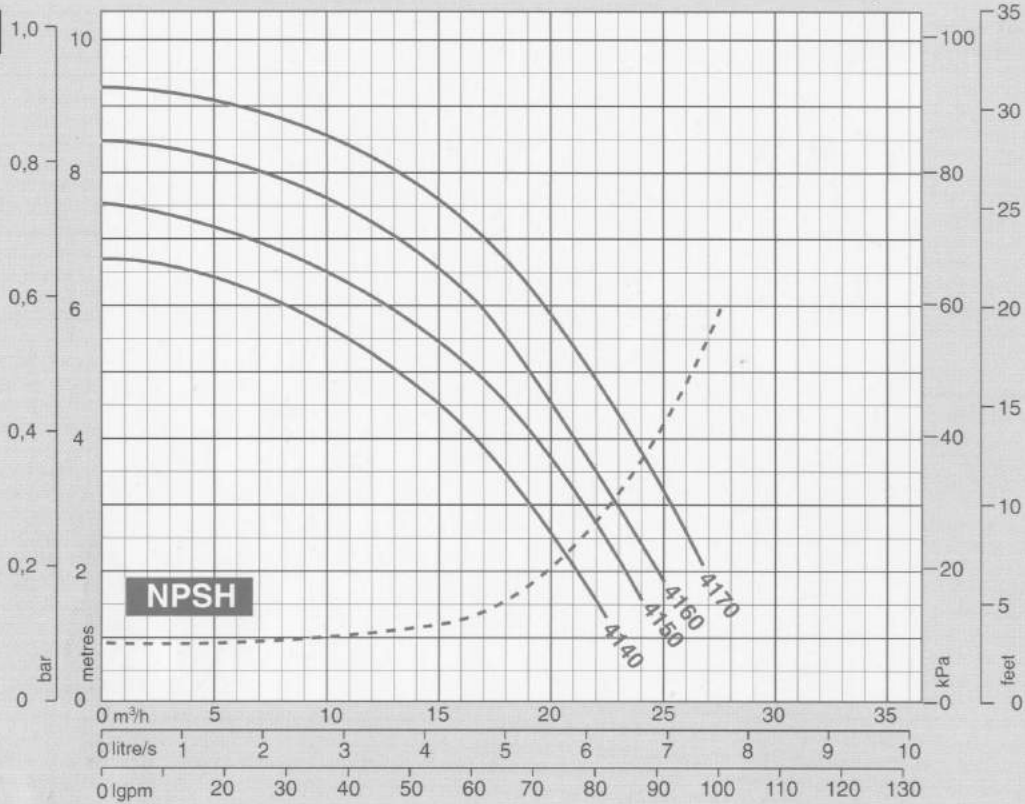

Pump Efficiency

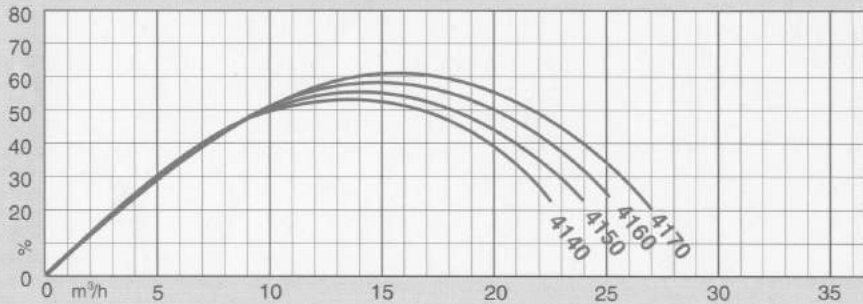

Motor Output

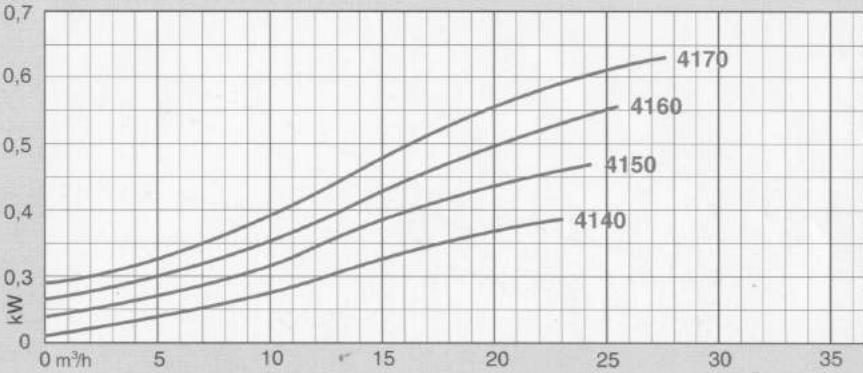

SG 65-4 Pole

1450 rev/min

- Impeller sizes up to 210mm -
50 Hz / 20°C

Performance

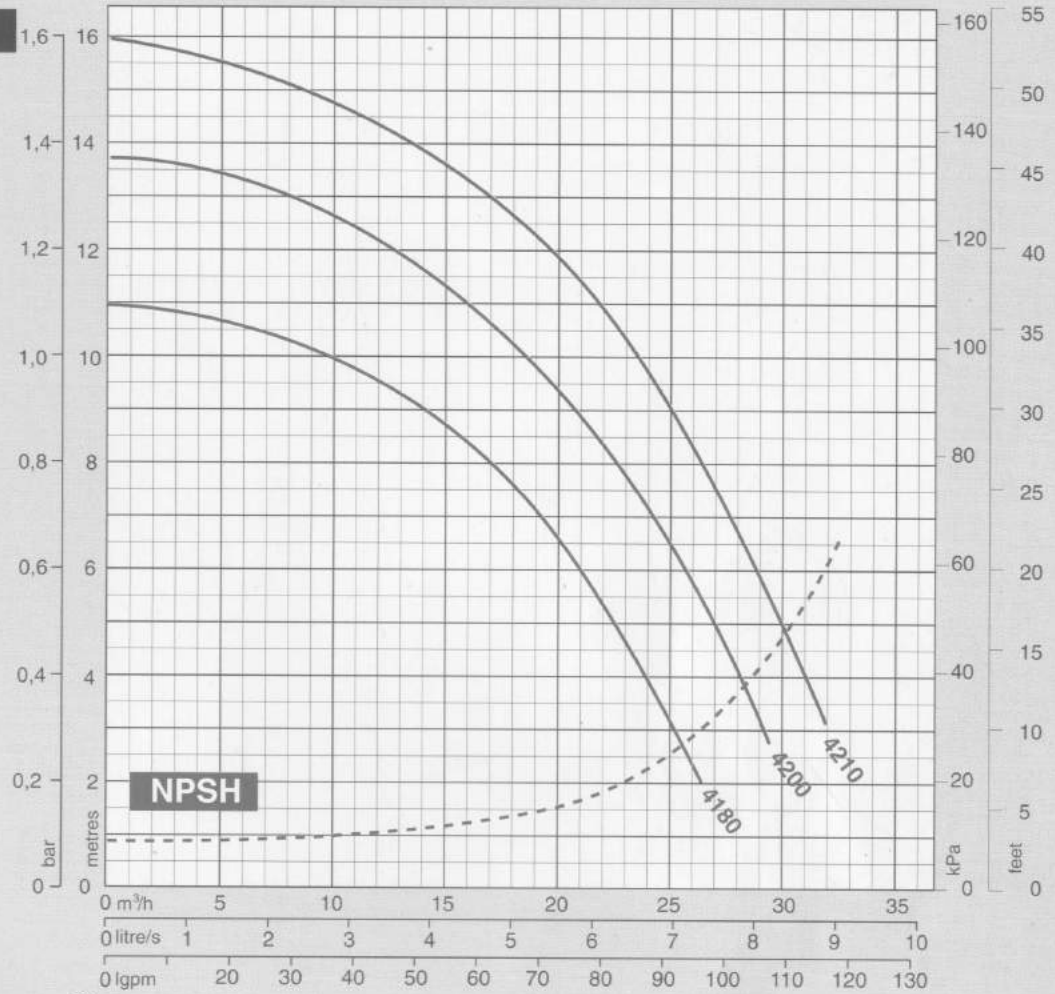

Pump Efficiency

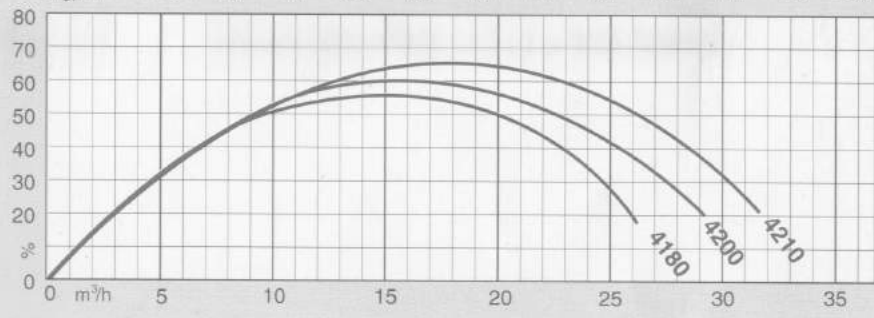

Motor Output

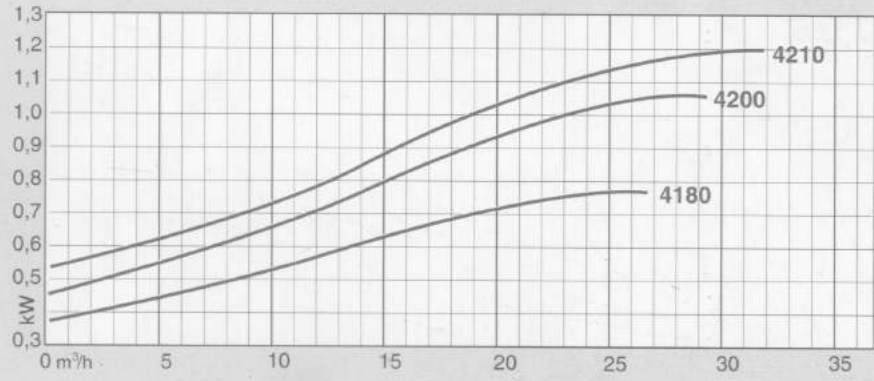

TECHNICAL DATA

SG 80-4 Pole
SG 100-4 Pole
1450 rev/min

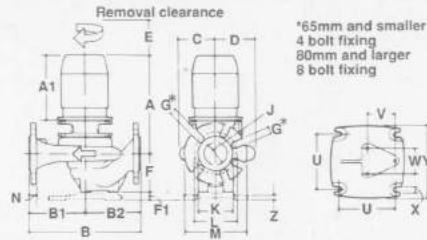
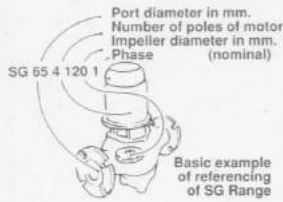

DIMENSIONS (mm) and WEIGHTS (kg)

SG 80-4 Pole

SG 100-4 Pole

	Pump body and motor											Flange						Baseplate						
	A	A1	B	B1	B2	C	D	E	F	F1	G	J	K	L	M	N	kg	U	V	W	X	Y	Z	kg
80-4260	485	350															98	225	112.5	125	18	300	17	7.9
80-4250	485	350															98							
80-4235	460	325	500	250	250	163	181										85							
80-4220	460	325															80							
80-4210	455	325															60	160	80	75	14	214	17	3.1
80-4200	455	325															60							
80-4185	405	280	450	225	225	142	156	125	135	25	8x18	80	120	145	200	24	52							
80-4175	380	255															48							
80-4170	380	255															45							
80-4160	380	255	400	200	200	120	140										43							
80-4150	355	230															41							
80-4130	335	210															35							
80-4120	305	205	360	180	180	103	125										33							
100-4260	575	405															135							
100-4250	575	405	560	280	280	180	190										135							
100-4235	540	370															124							
100-4220	490	350															103							
100-4210	455	325															75	225	112.5	125	18	300	17	7.9
100-4200	455	325	500	250	250	148	173	125	155	25	8x18	100	150	178	230	24	75							
100-4185	455	325															69							
100-4175	455	325															69							
100-4170	455	325															63							
100-4160	405	280	450	225	225	130	159										56							
100-4150	380	255															52							
100-4140	380	255															52							
100-4130	355	230															46							
100-4120	355	230	450	225	255	114	147										46							

MOTOR and SEAL DETAILS

SG 80-4 Pole

SG 100-4 Pole

	Frame Size IEC	Shaft Power kW	Speed rev/min	Full Load Current				Start Current Ratio %	Efficiency %	Power Factor	Seal Size mm
				at 500v A	at 415v A	at 380v A	at 220v A				
80-4260	112M	4.0	1440	6.8	8.1	8.9	15.3	670	83.5	0.82	24
80-4250	112M	4.0	1440	6.8	8.1	8.9	15.3	670	83.5	0.82	24
80-4235	100LB	3.0	1420	5.4	6.4	7.0	12.2	600	81.0	0.80	24
80-4220	100LA	2.2	1420	4.0	4.8	5.2	9.0	570	80.0	0.80	24
80-4210	100LA	2.2	1420	4.0	4.8	5.2	9.0	570	80.0	0.80	24
80-4200	100LA	2.2	1420	4.0	4.8	5.2	9.0	570	80.0	0.80	24
80-4185	90L	1.5	1415	2.8	3.4	3.7	6.5	530	77.0	0.79	18
80-4175	90S	1.1	1415	2.2	2.7	2.9	4.9	470	74.0	0.79	18
80-4170	90S	1.1	1415	2.2	2.7	2.9	4.9	470	74.0	0.79	18
80-4160	90S	1.1	1415	2.2	2.7	2.9	4.9	470	74.0	0.79	18
80-4150	80B	0.75	1400	1.46	1.76	1.92	3.3	470	76.0	0.78	18
80-4130	80A	0.55	1400	1.11	1.35	1.47	2.52	440	74.0	0.77	18
80-4120	71B	0.37	1400	0.87	1.05	1.15	1.98	350	69.0	0.71	13
100-4260	132M	7.5	1450	11.9	14.4	15.7	27.1	700	86.5	0.84	30
100-4250	132M	7.5	1450	11.9	14.4	15.7	27.1	700	86.5	0.84	30
100-4235	132S	5.5	1450	8.9	10.7	11.7	20.2	700	85.0	0.84	30
100-4220	112M	4.0	1440	6.8	8.1	8.9	15.3	670	83.5	0.82	30
100-4210	100LB	3.0	1420	5.4	6.4	7.0	12.2	600	81.0	0.80	24
100-4200	100LB	3.0	1420	5.4	6.4	7.0	12.2	600	81.0	0.80	24
100-4185	100LA	2.2	1420	4.0	4.8	5.2	9.0	570	80.0	0.80	24
100-4175	100LA	2.2	1420	4.0	4.8	5.2	9.0	570	80.0	0.80	24
100-4170	100LA	2.2	1420	4.0	4.8	5.2	9.0	570	80.0	0.80	24
100-4160	90L	1.5	1415	2.8	3.4	3.7	6.5	530	77.0	0.79	18
100-4150	90S	1.1	1415	2.2	2.7	2.9	4.9	470	74.0	0.79	18
100-4140	90S	1.1	1415	2.2	2.7	2.9	4.9	470	74.0	0.79	18
100-4130	80B	0.75	1400	1.46	1.76	1.92	3.3	470	76.0	0.78	18
100-4120	80B	0.75	1400	1.46	1.76	1.92	3.3	470	76.0	0.78	18

STAR/DELTA STARTING

For suitability with Star/Delta Starting please refer to relevant motor frame size.

- Frames 71-100:**
- Suitable (as standard) for dual voltage supplies and should be connected in Star for high voltages (eg 380-415v) or Delta for lower voltages (eg 220v).
 - May be started Star/ Delta if used on low voltage supplies.

- Frames 112-180:**
- Suitable (as standard) for Direct on Line (Delta Connection) or Star/Delta starting.

SG 80-4 Pole

1450 rev/min

- Impeller sizes up to 130mm -
50 Hz / 20°C

Performance

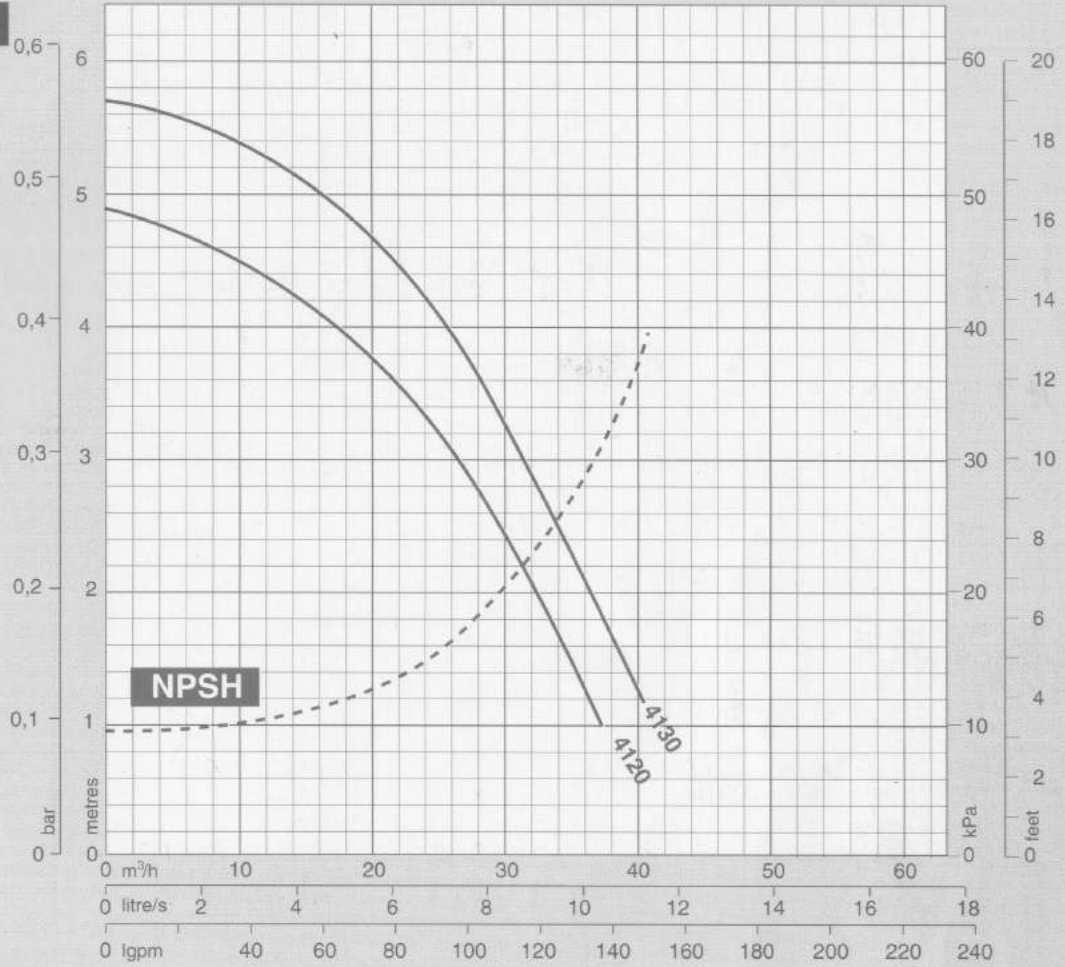

Pump Efficiency

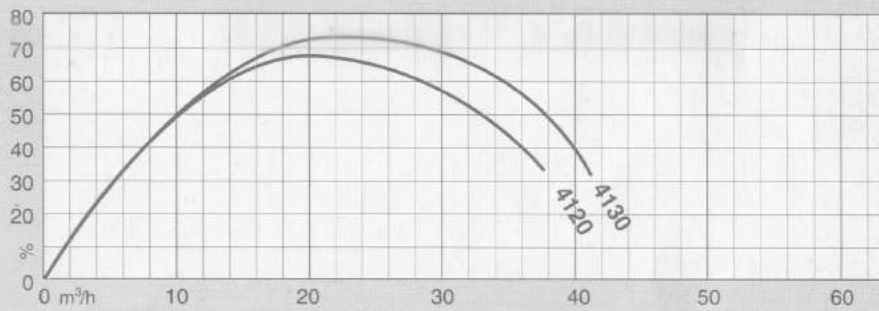

Motor Output

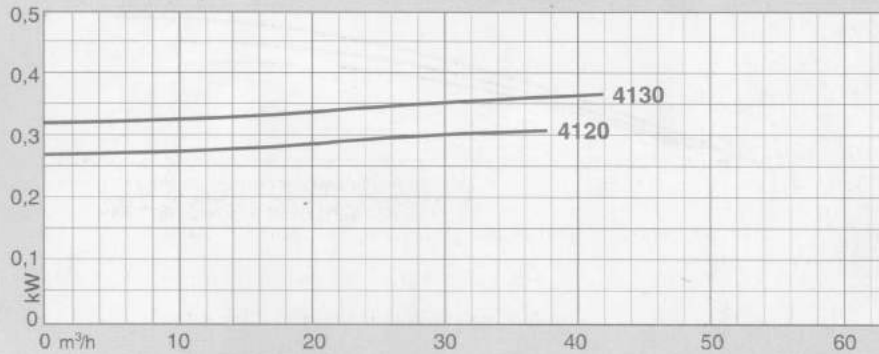

SG 80-4 Pole
1450 rev/min
 - Impeller sizes up to 170mm -
 50 Hz / 20°C

Performance

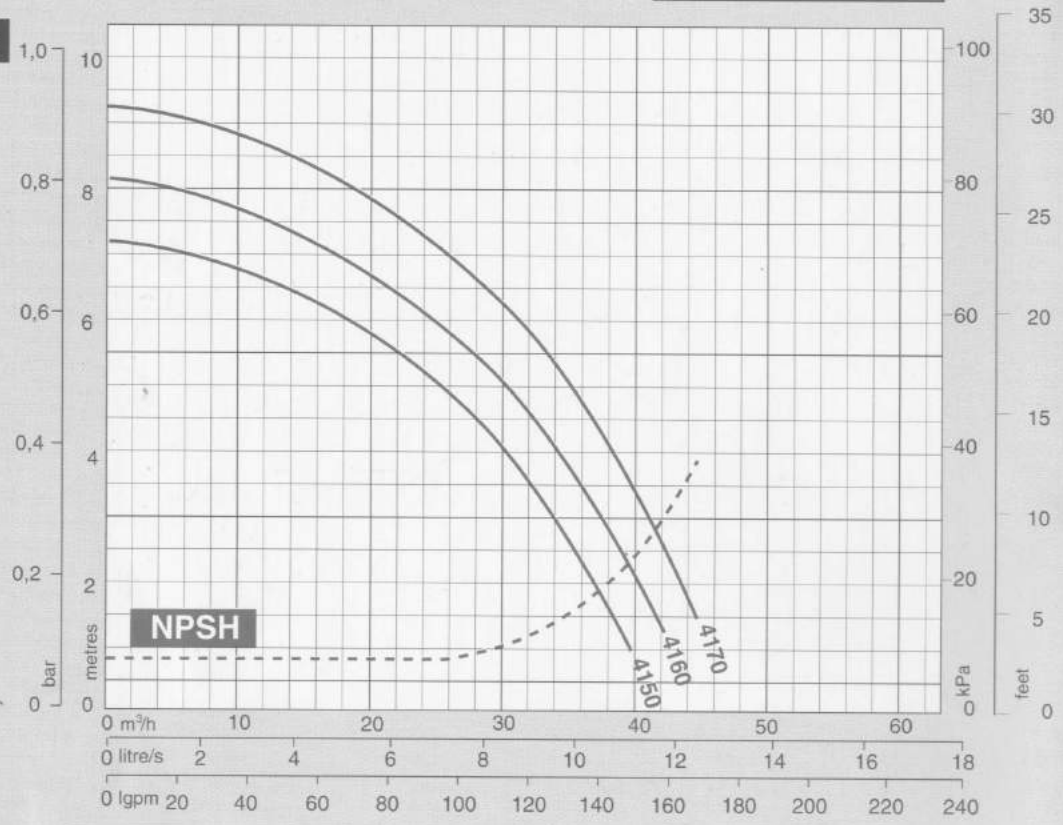

Pump Efficiency

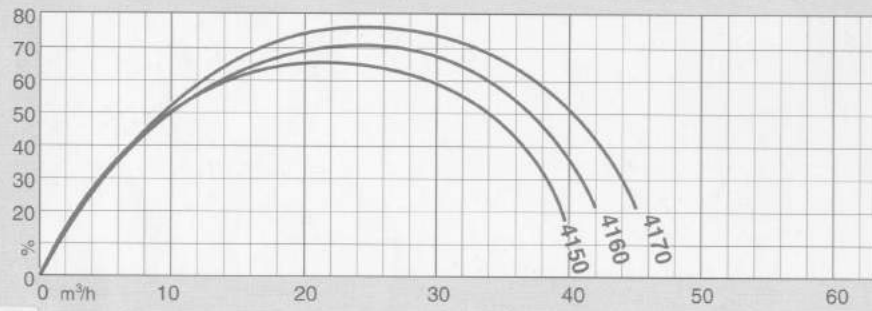

Motor Output

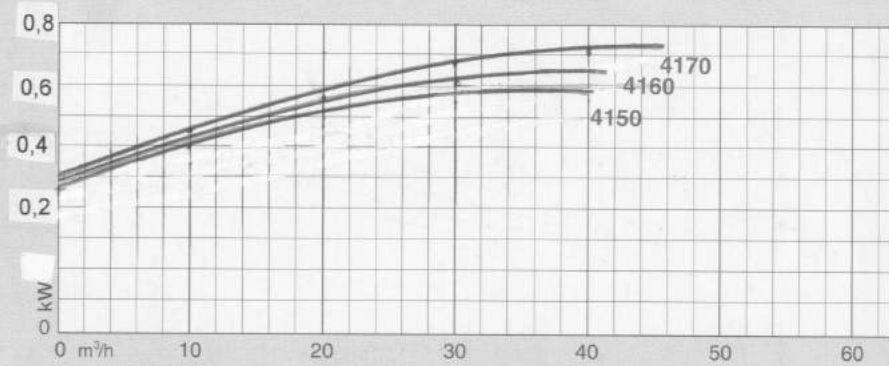

SG 80-4 Pole

1450 rev/min

- Impeller sizes up to 210mm -
50 Hz / 20°C

Performance

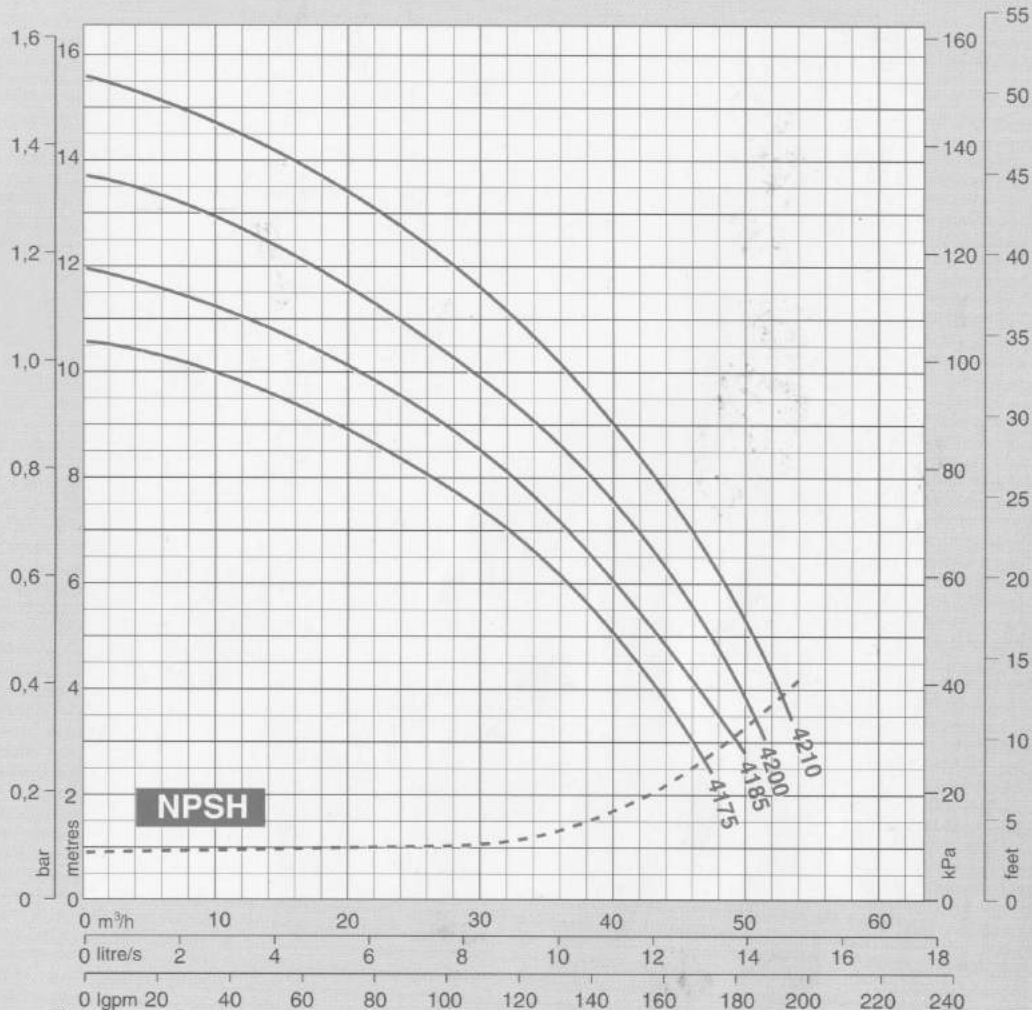

Pump Efficiency

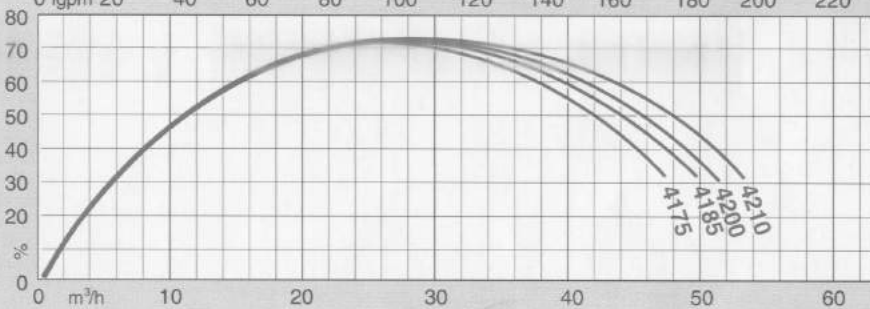

Motor Output

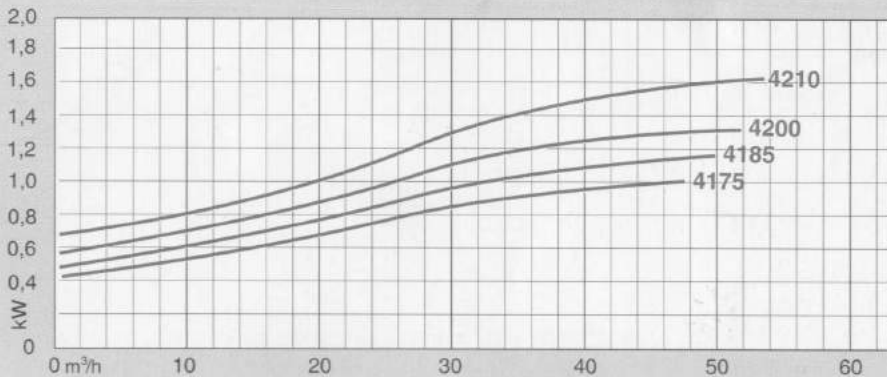

SG 80-4 Pole

1450 rev/min

- Impeller sizes up to 260mm -
50 Hz / 20°C

Performance

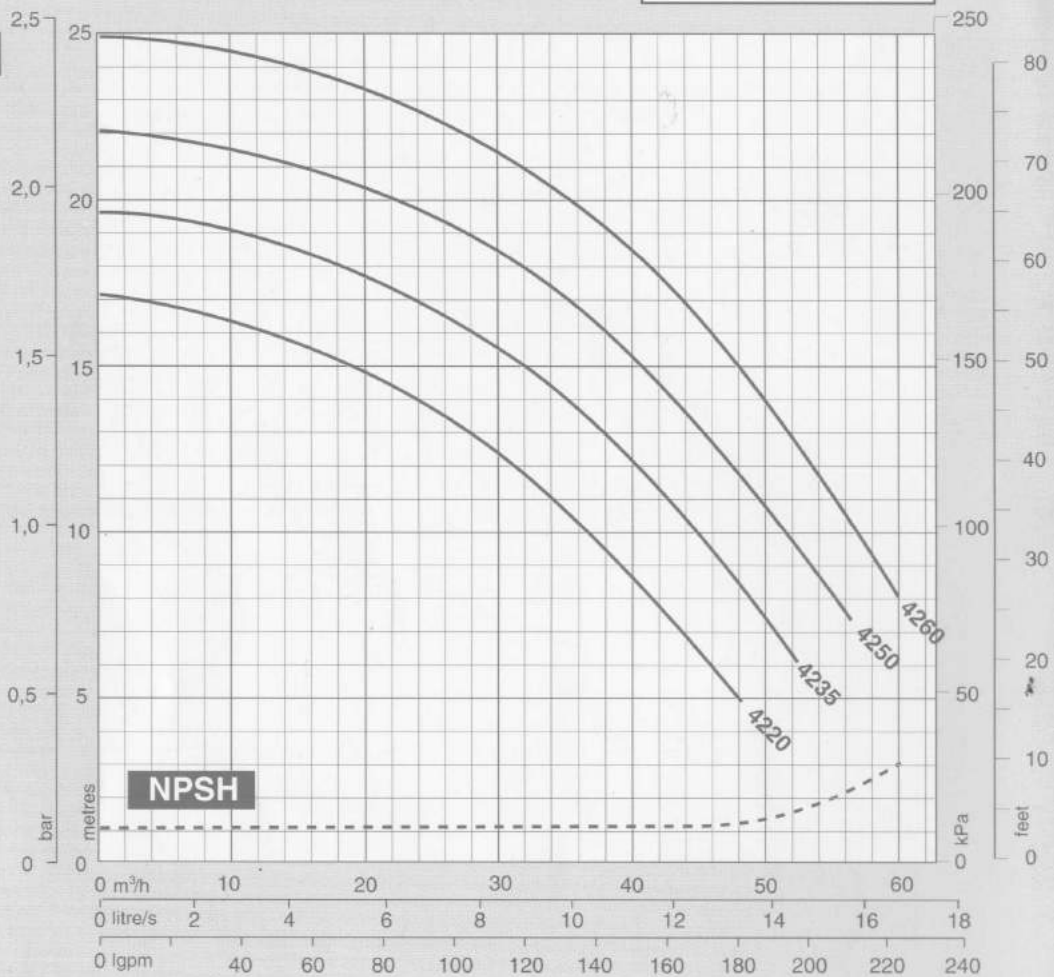

Pump Efficiency

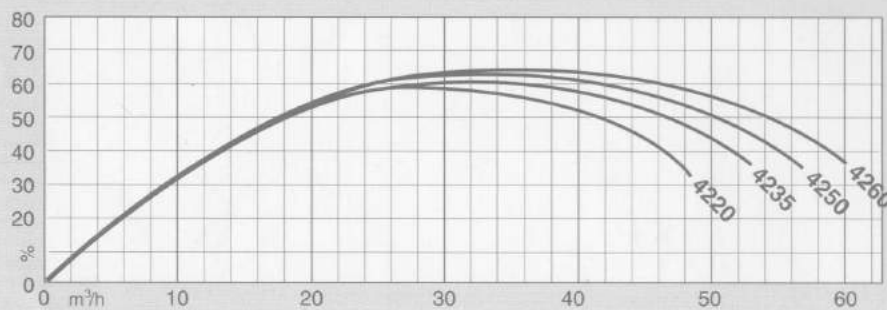

Motor Output

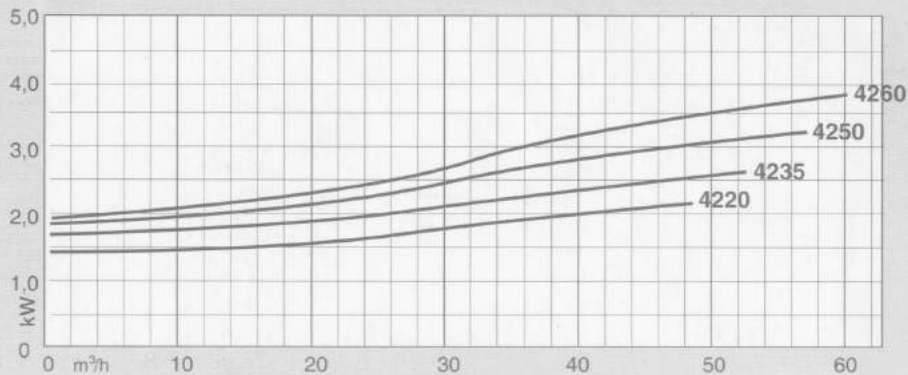

SG 100-4 Pole

1450 rev/min

- Impeller sizes up to 130mm -
50 Hz / 20°C

Performance

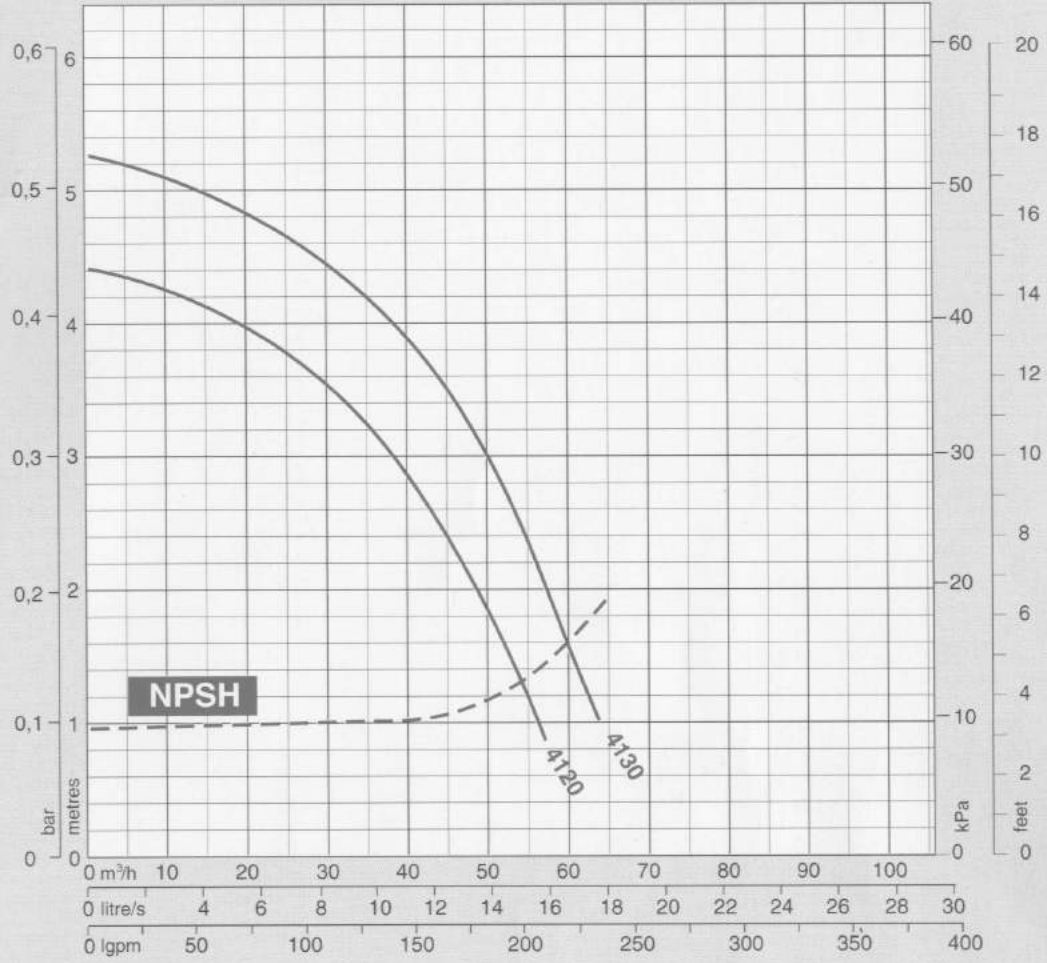

Pump Efficiency

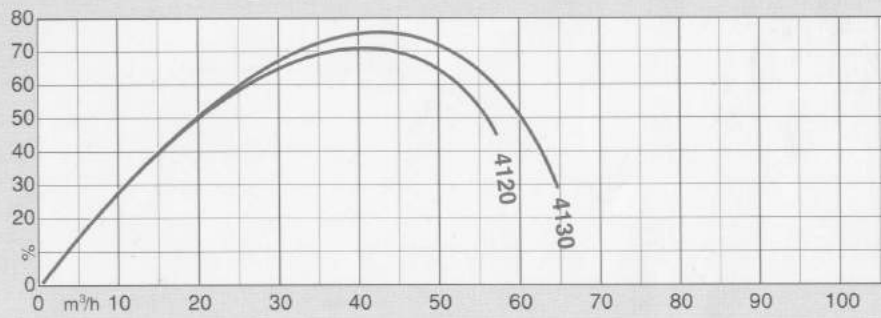

Motor Output

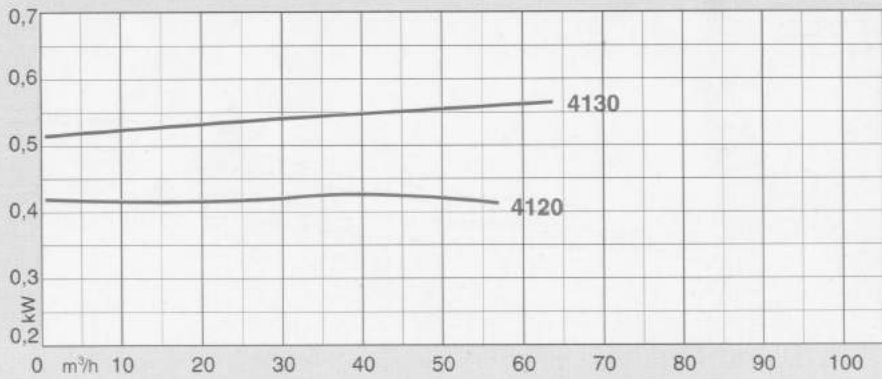

SG 100-4 Pole

1450 rev/min

- Impeller sizes up to 170mm -
50 Hz / 20°C

Performance

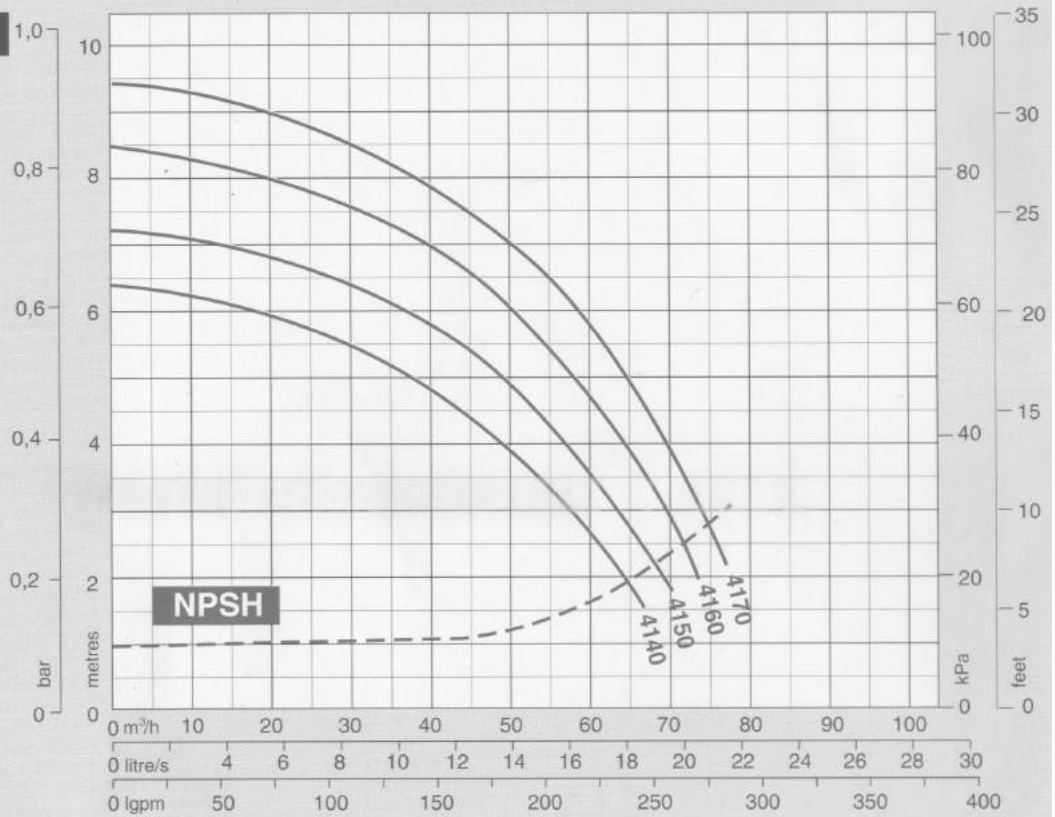

Pump Efficiency

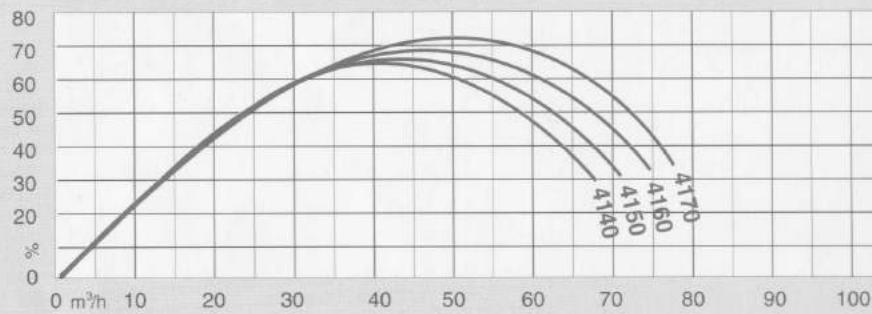

Motor Output

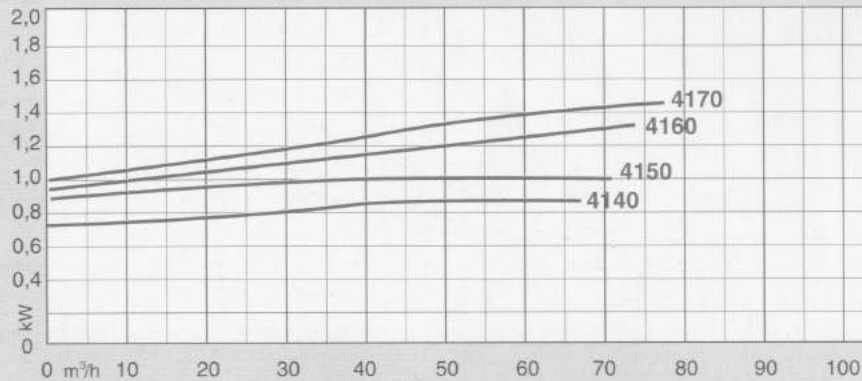

SG 100-4 Pole

1450 rev/min

- Impeller sizes up to 210mm -
50 Hz / 20°C

Performance

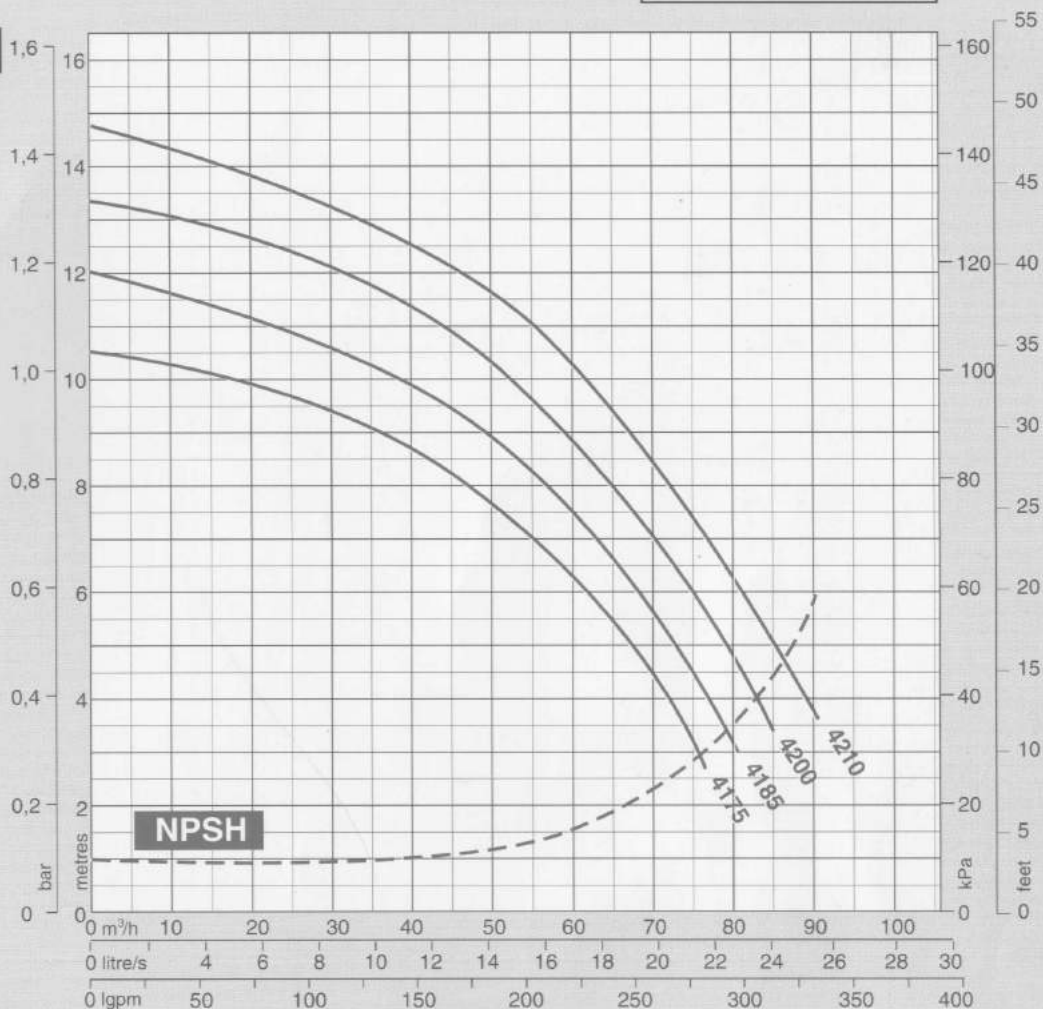

Pump Efficiency

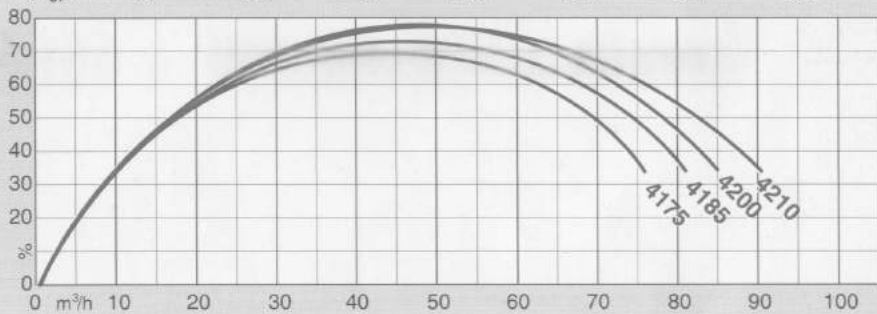

Motor Output

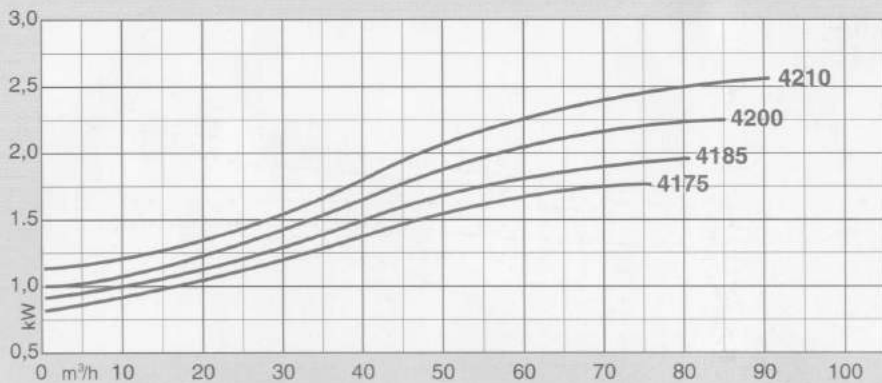

SG 100-4 Pole

1450 rev/min

- Impeller sizes up to 260mm -
50 Hz / 20°C

Performance

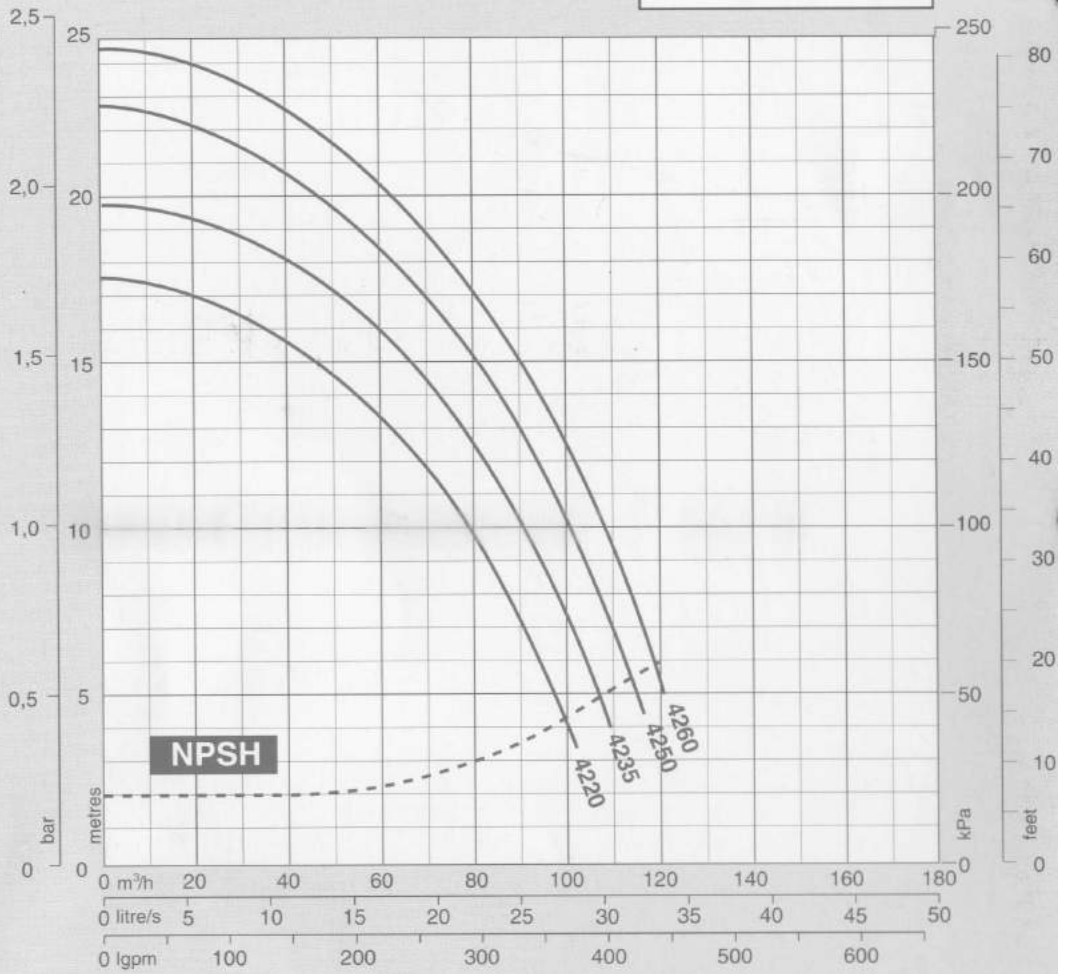

Pump Efficiency

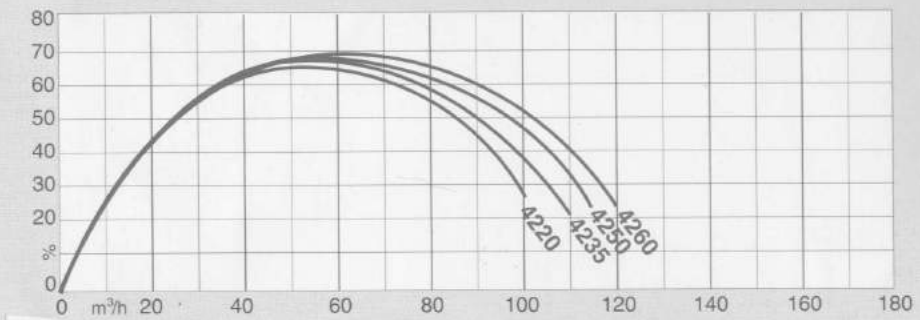

Motor Output

